

KELCO C25 FLOW SWITCH INSTALLATION AND OPERATION

The C25 inline flow switch is a 25mm or 1 inch magnetically actuated piston flow switch that is normally off and switches on in response to flow. It is suitable for many types of pressure boosting and control applications in both hot and cold liquids.

INSTALLATION

The C25 flow switch can be installed in any location in vertical or horizontal pipes. In vertical pipes flow can be either upward or downward through the switch. Where possible install a union on the inlet and outlet of the flow switch to allow easy removal for cleaning or servicing. Ensure the flow switch is oriented correctly to the direction of flow. Note that this flow switch may be supplied with either 1" BSP or 1" NPT threads. The male threaded end of the switch is the inlet. When installing make sure no thread tape or other material from the installation becomes entrained in the switch. Also ensure no foreign matter can enter the flow switch from tanks or pipework. Where scale or entrained material may be present always install a Y-strainer in the inlet pipe directly before the switch.

Note that this flow switch operates magnetically and is therefore not suited to any application where iron or iron scale may be present in the process liquid.

The electrical module that saddles the flow switch body can be removed or loosened if required to allow the body of the switch to be screwed into tight locations, for example into the discharge port of a pump. To completely remove the electrical module undo the 4 self-tapping screws that secure the two halves of the module together, the sealed electrical module then simply lifts off.

Under no circumstances should the C25-R module be operated electrically under a high amperage load unless suitably attached to the flow switch body.

REFITTING ELECTRICAL MODULES

The electrical module of the C25 flow switch can be oriented to suit the application. It can be mounted in either direction on the switch body and can be rotated around the switch body to any required position. All modules are normally off switches that turn on in response to flow. Reversing the orientation of the electrical module does not reverse the action of the switch. To refit a module to the switch body, fit and tighten the 4 stainless self-tapping screws.

CHECK VALVES

Many applications will benefit from a non-return valve in the pipework directly before the flow switch. This flow switch is not designed to operate as a one-way valve and rapid or high-pressure flow reversal may damage the piston in the switch. A simple non-return valve directly before the flow switch will reduce the possibility of damage due to flow reversal.

HOT LIQUIDS

This flow switch is suitable for use with hot or cold liquids up to 90°C continuous. Systems can be steam sterilized at 100°C for short periods without damaging the switch.

ELECTRICAL

The C25 flow switches are available in one of two basic electrical configurations. There is a model number and an electrical rating on the inside of every switch. The electrical rating of the two types of modules is set out in the following table.

ELECTRICAL DATA

Electrical Module	Module Type	Contact Configuration	Switched Power Maximum	Switched Voltage Maximum	Switched Current Resistive AC (rms)	Inductive Loads (Power Factor 0.4)	Typical Application
B	Dry contact reed switch	S.P.S.T Normally Open	40Watts	240V AC 200V DC	1 Amp Maximum	Not Suitable	PLC telemetry and relay logic circuits
R	Solid state switch	S.P.S.T Normally Open	3kW 4HP	5 to 240V AC	10mA Minimum 40 Amps Maximum	40 Amps at 240V	AC control circuits and motor control

Note: The switched power of the C25-R module given above refers to a switch operating in a water pipe system at ambient temperature. The solid state switch built into the C25-R can tolerate locked rotor motor currents to 40 Amps continuous.

FLOW SENSITIVITY

Sensitivity to flow depends on liquid viscosity and piston clearance. There are three pistons available to suit the C25 flow switch. These are designated and marked A, B and C. Switches are normally supplied with one of the three pistons pre-fitted. The table below shows the switch on and switch off flow rates for the three pistons. Pistons can be identified by a simple code of small pimples or bumps on the nose of each piston. The pimples are visible looking into the inlet end of the switch. One bump is the "A" piston, two is the "B" piston and three pimples is the "C" piston.

Piston Markings	Switching Point on a Slowly Rising Flow in Litres per Minute	Switching Point on a Slowly Reducing Flow in Litres per Minute	Electrical Response Time in Seconds
1 = A	1.0	0.6	0.1
2 = B	4.0	3.2	0.1
3 = C	8.0	5.5	0.1

Note: The data shown in the table above refers to water at ambient temperature as the test medium. Increasing fluid viscosity will decrease the switch on points. Decreasing the fluid viscosity will proportionally increase the switch on points.

GENERAL LAYOUT

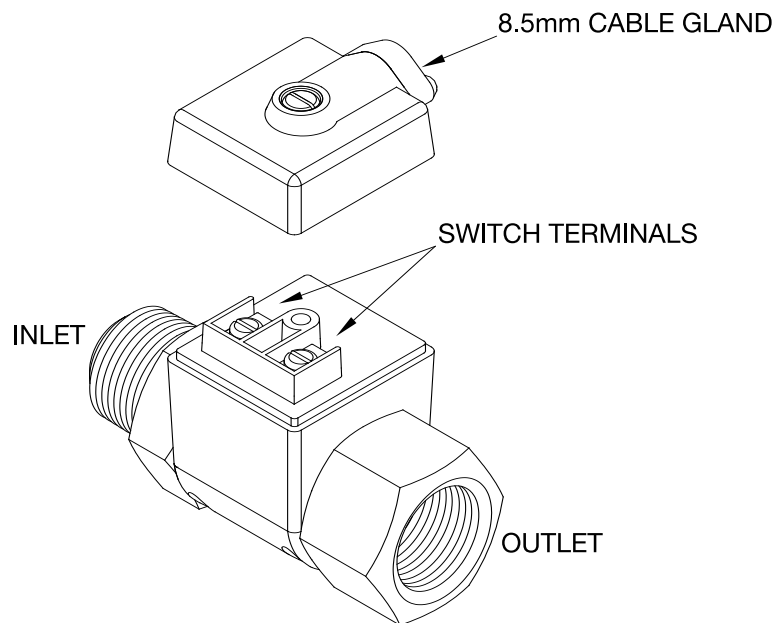

SERVICING

The C25 flow switch operates magnetically. The piston within the switch body should be a free fit and spring back to its off position as soon as flow stops. To test the flow switch push your finger into the inlet of the switch and press the piston back as far as it can go. When released, the piston should spring back freely. If the piston becomes jammed, it may require removal and cleaning.

Using a pair of long nosed pliers remove the spring circlip located in the outlet port of the switch. Press the piston back with your finger, it should pop out along with its three finned magnetic spider. Ensure there are no pieces of iron scale adhered to the piston or spider and that both parts are free of damage. Reassemble the switch and test it to ensure the piston is a free and smooth fit. The C25-B flow switch can be tested electrically using a continuity tester. The switch should be initially off and switch on when the piston is pushed back. The model C25-R should only be tested with a lamp load on an AC supply. The test lamp should light each time the piston is pushed back. If the C25-R is tested for continuity using an Ohms meter, a high resistance reading will be present across the switch terminals regardless of the ON or OFF state of the switch. This resistance is due to the solid state switch, and equates to a very small current leak present at all times across the contacts of the switch. The C25-R flow switch should not be used in AC applications that draw very small currents (<10mA), for example to drive electronic timers, as the load may remain in an on state regardless of the state of the flow switch, this effect is due to the small leakage current through the flow switch.

MADE IN AUSTRALIA BY

KELCO Engineering Pty Ltd

ABN 20 002 834 844

Head office and factory

9/9 Powells Road Brookvale 2100 NSW Australia

Phone: +61 2 9905 6425 Fax: +61 2 9905 6420

Email: sales@kelco.com.au Web: www.kelco.com.au

©2008 Kelco Engineering Pty Ltd

PLEASE NOTE: Kelco Engineering Pty Ltd reserves the right to change the specification of this product without notice. Kelco Engineering Pty Ltd accepts no liability for personal injury or economic loss as a consequence of the use of this product. All rights reserved copyright Kelco Engineering Pty Ltd © 2008.