

D30 SERIES LIQUID LEVEL SWITCH

FEATURES

- FULLY ADJUSTABLE TWO POSITION SWITCHING
- 2 HP RATED 20 AMP S.P.D.T. SWITCH
- NO METAL PARTS IN CONTACT WITH LIQUIDS
- -1 TO 18 BAR PRESSURE RATING
- ALL THERMOPLASTIC CONSTRUCTION
- WEATHERPROOF HOUSING
- SUPER RELIABLE MAGNETIC ACTION
- UNIVERSAL MOUNTING BRACKET SUPPLIED

APPLICATIONS

- SUMP PUMP CONTROL
- FOR EITHER PUMP IN OR PUMP OUT
- WATER TANK LEVEL CONTROL
- EFFLUENT AND LIQUID WASTE LEVEL CONTROL
- SUITS SLURRIES AND HIGH SOLIDS APPLICATIONS
- SEPTIC AND SEWER PUMPOUT CONTROL
- COOLING TOWER CONTROL SYSTEMS
- SUITS FROTHING FOAMING OR AGITATED LIQUIDS
- SUITABLE FOR SEA WATER, ACIDS & MANY CHEMICALS
- WORKS IN SUMPS, PITS, BORES, TANKS, WELLS OR BUNDS
- CAN BE USED IN PRESSURE OR VACUUM VESSELS

Modern thermoplastic piping and tank systems demand modern controls. The D30 level switch is a rugged versatile liquid level switch that integrates states of the art magnet technology with one of the most fundamental principles of physics to achieve a sensible and reliable solution to the problem of controlling the level of liquids in tanks and sumps.

OPERATING PRINCIPLE

The D30 two position top entry level switch operates on the principle of displacement. When non floating solid polypropylene displacers, suspended from the switch, are immersed in liquid their weight is reduced by an amount equal to the weight of the liquid they displace, This weight change is detected and used to actuate a magnetically isolated switch. Surface agitation, froth, floating or submerged solids do not effect the action of the D30 switch. The displacement principle depends on the specific gravity of the liquid in which the displacers are suspended. The switch is set to operate in water, at a specific gravity of 1+/- 5%. Various displacers are also available to allow the switch to operate in liquids of other specific gravities.

CONSTRUCTION

The electrical housing and body of the D30 level switch are constructed from impact resistant ultraviolet stabilized ABS thermoplastic. The solid displacers are made from glass-reinforced polypropylene, and the suspension cord is made from virgin polypropylene. On the underside of the switch body is a standard 20 NB (pipe size) male spigot. The spigot can be either fitted into, or glued into any standard PVC or ABS pipefitting such as flanges, unions or reducing bushes. In addition each switch is supplied with a universal mounting bracket suitable for direct fixing to walls, tank lids or horizontal pipework. The displacers suspended from the switch fit easily inside 50mm nominal size PVC pipe. This feature allows the switch to be simply and quickly mounted in stilling wells, by-pass housings or in stand off risers. Such mounting can be constructed from standard off the shelf PVC or ABS pipe and fittings. The D30 level switch has no metal



AUSTRALIAN MADE

TECHNICAL DATA

parts that come into contact with liquids, regardless of the mounting method used. The actuation arm operates the switch by magnetic force, through a solid barrier of ABS. This means the switch can be used in pressure vessels or in applications where the entire displacer and cord assembly are under pressure or vacuum.

HAZARDOUS AREA USES

The D30 liquid level switch is a mechanically self-actuating device in which there is no mechanism for the production or storage of electrical energy. As such the D30 is classed as a simple device. No separate certification is required to use the switch in an explosion prone environment. In hazardous applications, the switch should be isolated via an intrinsically safe relay, a zenner barrier.

APPLICATIONS

The D30 level switch is designed to detect a level change in liquids that have a specific gravity of one, that is, water or water that contains dissolved or suspended solids. The switch can be mounted in any location above the liquid being sensed. The twist lock displacers are positioned on the cord at points where the switch is required to change state, for example close to the bottom of a tank for the low level switching point and close to the top of a tank for the high level switching point. A falling liquid level will trip the switch when the bottom displacers are partly uncovered, and a rising liquid level will reset the switch when the top displacers are partly submerged. A 20 Amp single pole double throw switch is provided so circuits can be switched on or off when liquid is either rising or falling, making the switch ideal for both pump in and pump out applications. The switch mechanism built into the D30 is a special high current high capacity device, capable of directly controlling pump motors up to 2 HP at 240 VAC. For less demanding applications, the switch is equally capable of actuating relays, contactors or PLC's.

OPERATING PARAMETERS

Minimum level differential	150mm, (with 3 displacers stacked tightly together)
Maximum level differential	20 Metres, (3 Metres of cord supplied with switch)
Minimum distance from switch point to floor of a tank or sump.	40mm (Sumps can be pumped out to within 40mm of floor)
Maximum pressure, at ambient temperature	18 Bars (Where the displacers are in a pressure vessel)
Minimum burst pressure, at ambient temperature	80 Bars
Minimum pressure	-1 Bar (Where the displacers are under vacuum)
Maximum liquid temperature, (in open tank non pressure applications)	100°C (Displacers & cord only can withstand this temperature.)
Maximum liquid temperature, (where switch housing is exposed to hot liquid), at Ph 7	60°C (This temperature must be de-rated in pressure vessel applications.)
Ph Range	1 to 14 (At ambient temperature)
Specific Gravity of process liquid	1.0 +/- 5%
Ingress Protection rating (Housing)	IP 67

Some suggested methods of mounting the D30 Level Switch.

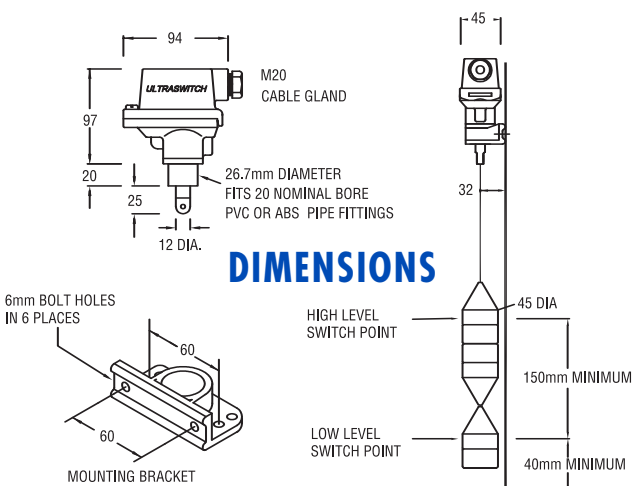
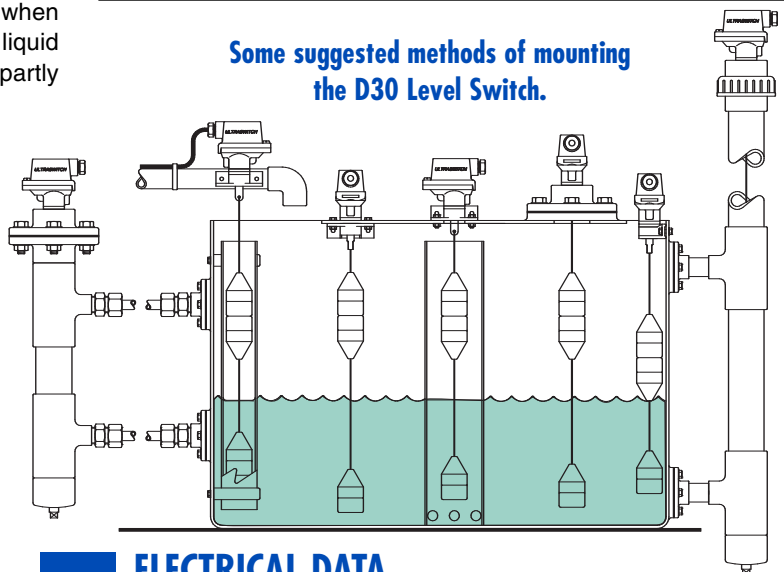

DIMENSIONS

ELECTRICAL DATA

The D30 level switch contains a high capacity single pole double throw microswitch with Tungsten contacts, specifically designed to control motor loads up to 2 Horse Power.

Rated Voltage	NON INDUCTIVE LOADS				INDUCTIVE LOADS			
	Resistive load		Lamp Load		Inductive Load		Motor Load	
	NC	NO	NC	NO	NC	NO	NC	NO
125 VAC	20 A		7.5 A		20 A		12.5 A	
250 VAC	20 A		7.5 A		20 A		8.3 A	
500 VAC	15 A		4 A		10 A		2 A	
8 VDC	20 A		3 A	1.5 A	20 A		12.5 A	
14 VDC	20 A		3 A	1.5 A	15 A		12.5 A	
30 VDC	6 A		3 A	1.5 A	5 A		5 A	
125 VDC	0.5 A		0.5 A		0.05 A		0.05 A	
250 VDC	0.25 A		0.25 A		0.03 A		0.03 A	

MADE IN AUSTRALIA BY

KELCO Engineering Pty Ltd

ABN 20 002 834 844

Head office and factory

9/9 Powells Road Brookvale 2100 NSW Australia

Phone: +61 2 9905 6425 Fax: +61 2 9905 6420

Email: sales@kelco.com.au Web: www.kelco.com.au

©2008 Kelco Engineering Pty Ltd

PLEASE NOTE: Kelco Engineering Pty Ltd reserves the right to change the specification of this product without notice. Kelco Engineering Pty Ltd accepts no liability for personal injury or economic loss as a consequence of the use of this product. All rights reserved copyright Kelco Engineering Pty Ltd © 2008.