

INSTALLATION AND OPERATING INSTRUCTIONS FOR ULTRASWITCH D30 DISPLACEMENT LEVEL SWITCH

INTRODUCTION

The D30 top entry level switch is a two position level regulator capable of controlling both the high and low level switching points of a pump or contactor set to pump liquid in or out of a pit or tank. The D30 level switch operates by Archimedes Principle. When an object is immersed in liquid its weight is reduced by an amount equal to the weight of the liquid it displaces. In the D30 switch a magnetically actuated microswitch detects the weight change that occurs when liquid submerges a set of solid polypropylene displacers suspended from the switch. Since it is weight change that actuates the switch, specific gravity, or weight per unit volume of the liquid medium is critical to the operation of the switch. The standard D30 level switch is set up to operate in water (with a specific gravity of 1.0 plus or minus 5%). Special displacers are available to suit liquids of other specific gravities.

The actuating arm of the D30 switch is encased in a blind cavity in the switch body. The microswitch in the electrical housing is actuated magnetically through the solid body of the switch. In pressure applications the entire arm and housing can be pressurised with no detrimental effect to the working of the switch. There are no electrical components in contact with the process liquid and no seals or other points of potential failure.

OPERATING ENVIRONMENT

The D30 level switch is an extremely versatile device. It can be used to control the level of liquid in wells, tanks, pits, sumps, bores, or in pressure or vacuum vessels, in fact virtually anywhere liquid is rising or falling in level. It can be used in potable water, distilled water, seawater or water that contains solids, pulp, froth, foam, grit or waste materials. The weatherproof electrical housing of the switch is normally mounted above the liquid to be sensed, and the solid displacers suspended by cord at the points where the rising or falling liquid levels are required to operate the switch. The suspension cord and the displacers are the only components of the switch that come in contact with the liquid, and these are made from inert polypropylene. Polypropylene is highly regarded for its chemical resistance. The specific chemical resistance for Polypropylene can be found in widely available chemical compatibility charts. Essentially the D30 level switch can be used in any liquid of S.G. that does not affect polypropylene, and at any temperature within the limits of tolerance of the displacers and cord.

INSTALLATION

Fig. 1 shows some suggested methods of mounting the D30 switch. These include bracket mounts, pressure vessel mounting and the use of PVC or ABS pipe to fabricate stilling wells or shrouds to house the switch. Whatever method is used, it is critical to the correct operation of the switch that it be mounted absolutely vertically. The switch can be simply mounted in its bracket, or for pressure applications, solvent glued into standard PVC or ABS pipefittings. The displacers are designed to fit down the inside of 50NB PVC class 18 pipe. Such pipe can provide an excellent housing and carrier for the displacer assembly. When glueing the switch into pipefittings, take care not to use excess glue and not to allow glue to make contact with the actuating arm of the switch.

Cord length and the position of the displacers on the cord are fully user adjustable. Take care to ensure the bottom displacers do not touch the bottom of the tank, or the switch will not operate. The standard D30 switch is supplied with 3 metres of cord. Any required cord length can be used with the switch, and the bottom end of the cord should be knotted to prevent the displacers sliding off during adjustment or commissioning.

EXPOSED APPLICATIONS

If this switch is to be mounted in an outside location, for example on top of an open water tank we recommend the switch be mounted in a shroud made from 50mm PVC. A simple pipe shroud, particularly if it is painted will protect the switch from reflected UV sunlight, and thus prevent degradation of the cord and top displacers. This simple precaution will greatly prolong the life of the switch.

Fig 1 Some suggested methods of mounting the D30 Level Switch

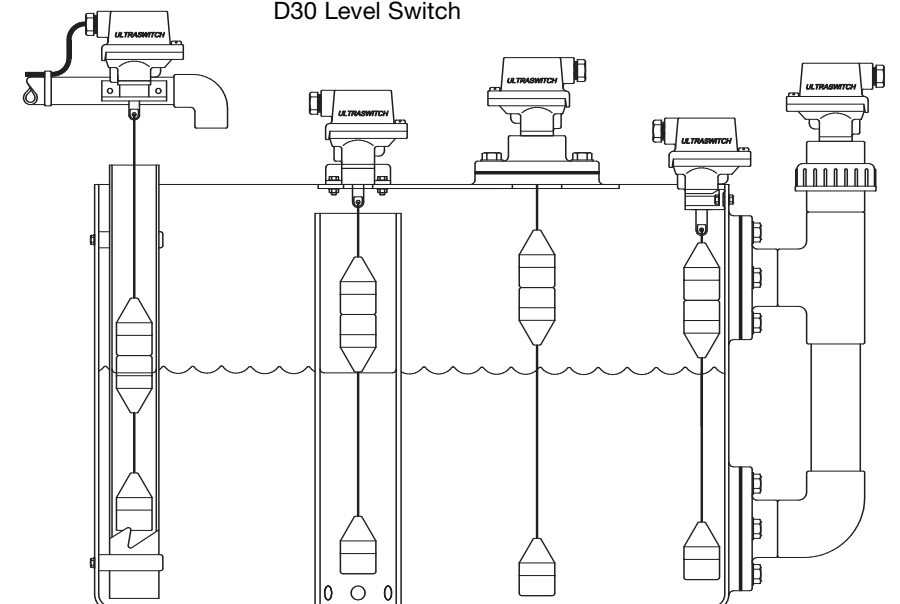

ELECTRICAL

The D30 switch houses a single pole double throw microswitch. Details of the layout of the switch and the terminal designation are shown in the sketch. On a rising liquid level Common to Normally open is closed and Common to Normally Closed is open. On a falling liquid level, the switch reverses state that is Common to Normally open is open and Common to Normally closed is closed. This allows the switch to be configured for either pump out or pump in applications.

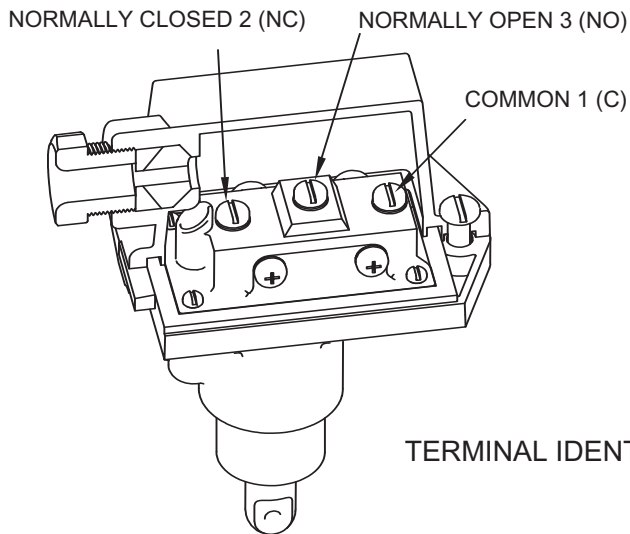

TERMINAL IDENTIFICATION

Note

To pump out of a tank, use terminals 1 (C) and 2 (NC)
 To pump into a tank, use terminals 1 (C) and 3 (NO)

MAINTENANCE & ADJUSTMENT

The D30 level switch is supplied pre-set but when required, the switching point in relation to specific gravity is adjustable via an Allen head screw accessed through a port at the end of the microswitch. Under normal circumstances the adjusting screw should not be altered. It is factory set and will only require adjusting if the switch is to be set up to operate in liquids at an SG other than 1.0. When maintenance is required, all components of the D30 level switch are available as spare parts; the body of the switch with the actuating arm included is one complete assembly and is non-serviceable. The actuating arm cannot be removed from the housing.

- 1) THREAD CORD THROUGH THE 3 COMPONENTS
- 2) LAY THE CORD IN THE TRENCH IN THE ANVIL
- 3) SLIDE THE ANVIL INTO THE TOP BODY HALF
- 4) SCREW THE TWO BODY HALVES TOGETHER
- 5) TIE A KNOT IN THE FREE END OF THE CORD

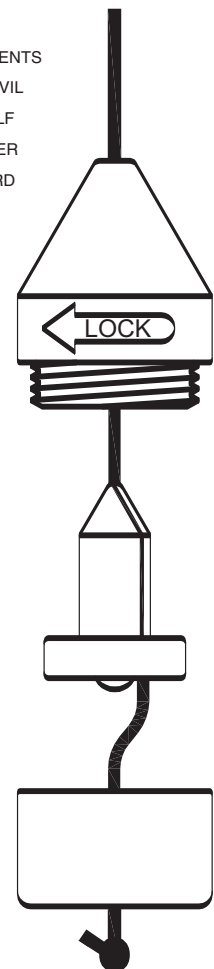

Fig 2 DISPLACER ASSEMBLY

ELECTRICAL DATA

The D30 level switch contains a high capacity single pole double throw microswitch with Tungsten contacts, specifically designed to control motor loads up to 2 Horse Power.

Rated Voltage	NON INDUCTIVE LOADS				INDUCTIVE LOADS			
	Resistive load		Lamp Load		Inductive Load		Motor Load	
	NC	NO	NC	NO	NC	NO	NC	NO
125 VAC	20 A		7.5 A		20 A		12.5 A	
250 VAC	20 A		7.5 A		20 A		8.3 A	
500 VAC	15 A		4 A		10 A		2 A	
8 VDC	20 A		3 A	1.5 A	20 A		12.5 A	
14 VDC	20 A		3 A	1.5 A	15 A		12.5 A	
30 VDC	6 A		3 A	1.5 A	5 A		5 A	
125 VDC	0.5 A		0.5 A		0.05 A		0.05 A	
250 VDC	0.25 A		0.25 A		0.03 A		0.03 A	

MADE IN AUSTRALIA BY

KELCO Engineering Pty Ltd

ABN 20 002 834 844

Head office and factory

9/9 Powells Road Brookvale 2100 NSW Australia

Phone: +61 2 9905 6425 Fax: +61 2 9905 6420

Email: sales@kelco.com.au Web: www.kelco.com.au

©2008 Kelco Engineering Pty Ltd

PLEASE NOTE: Kelco Engineering Pty Ltd reserves the right to change the specification of this product without notice. Kelco Engineering Pty Ltd accepts no liability for personal injury or economic loss as a consequence of the use of this product. All rights reserved copyright Kelco Engineering Pty Ltd © 2008.