

# INSTALLATION AND OPERATING INSTRUCTIONS FOR TW26 TRAILING WIRE FLOW SWITCHES

**PLEASE READ THIS INSTALLATION SHEET CAREFULLY AND FULLY  
BEFORE INSTALLING OR SERVICING THIS FLOW SWITCH.**

## INTRODUCTION

The TW26-S and TW26-SS trailing wire flow switches are heavy duty flow sensors that use a flexible stainless wire rather than a conventional paddle to sense fluid flow. They are suitable for sensing flow in open discharge applications or in pipes of any diameter from 25mm upwards. The flexible stainless wire sensor offers major advantages over conventional paddles when used in situations where solids or semi-solids are present, such as in sewerage pumping applications. They are also suitable for use in slurry and mining applications and in many normal pumping situations where the flow velocity is high and conventional paddles are unsuitable.

The TW26 trailing wire flow switch is available in two models, an all Polypropylene version, designated TW26-S and an Polypropylene / 316 stainless steel model TW26-SS. Both models are identical with the exception of the stainless body. The standard all Polypropylene switch is suitable for most applications where static or dynamic pressures are less than 18 Bars. The stainless version can safely tolerate pressures to 100 Bars. The TW26-SS has the advantage of higher mechanical strength and finds application in fire prone or vandal prone areas.

## APPLICATIONS

It is not possible to give definitive data on the actual flow rates required to actuate the TW26 flow switch. Every installation is unique and many factors interact to influence exactly how the sensor will respond. Depending very much on wire length and submergence, a minimum fluid velocity of around 0.2 Metre per second is required to reliably actuate the switch. In low flow situations the cross section of the channel or pipe can be reduced to increase the local velocity sufficient to actuate the TW26 switch. The degree of submergence of the trailing wire and the distance from the liquid surface to the switch, the viscosity and amount and nature of any entrained matter in the fluid stream will also affect the switch's action.

The TW26 flow switches are principally intended to be mounted above and clear of the surface of the liquid to be monitored. The only part of the switch in contact with the liquid should be the trailing wire. There are a number of variations of this principle that can be used to advantage. For example the switch can be bracketed in front of an open discharge pipe with the trailing wire displaced only when fluid flows. Equally the switch can be screwed through an inspection cover, with the flexible wire trailing into a partly filled pipe.

## OPERATING ENVIRONMENT

Maximum operating pressure (static or dynamic) at ambient temperature.	20 Bars (290 PSI) polypropylene model 100 Bars (1450 PSI) Stainless model
Minimum burst pressure at ambient temperature.	80 Bars (1160 PSI) polypropylene model 400 Bars (5800 PSI) Stainless model
Maximum operating temperature (Liquid)	80 Degrees C at a pressure 1 bar absolute, see note below
Minimum operating temperature (Liquid)	-30°C
Process liquid Ph range	6.8 to 14
Ingress protection rating (Housing)	IP67

**Note:** Temperature for the maximum operating pressure shown in the above operating environment table is 15°C. In the interest of safety, when using the polypropylene version of the TW26 series, maximum operating pressure must be de-rated linearly in direct proportion to temperature increase, to a maximum pressure of 1 bar absolute at 80 degrees Centigrade. In other words only use this switch at elevated temperatures in non pressurised systems that are totally open to atmosphere in all circumstances and under all conditions.

## INSTALLATION

The nature of the trailing wire flow switch is such that it lends itself to innovative applications. For example the switch can be used to detect solid objects moving on a conveyor belt and as an alternative to photoelectric sensors in many dusty and dirty environments. Equally the switch can be used to detect water flow in rivers, open channels or pipes.

Consider your application carefully and try to mount the switch as far above the material to be detected as possible. In slow flowing liquid applications it will generally not be known what degree of submergence of the trailing wire will be required to operate the switch. If possible in such situations hold the switch above the moving liquid and slowly lower the end of the wire into the liquid until the switch arm swings downstream and the switch clicks to the on position. Observe the amount of submergence and mount the switch accordingly. Avoid mounting the switch in situations where the trailing wire is liable to trail into valves, pumps or any object liable to be damaged, or to damage the wire. If the switch is to be used in a conventional pipework situation, select a location for the flow switch in a straight run of pipe ideally with five pipe diameters of straight pipe either side of the switch. This will ensure a linear non turbulent flow acts against the trailing wire sensor.

Do not install the trailing wire flow switch in any location likely to expose it to excessive turbulence, such as directly adjacent to valves or pumps, pipe bends or elbows. The object is to achieve a smooth flow against the wire sensor of the switch and thus obtain a stable non-chattering response from the flow switch. The TW26 flow switch can be mounted in either the suction or discharge pipe of a pump, the switch will respond equally well in a negative pressure situation as well as in a positive pressure application.

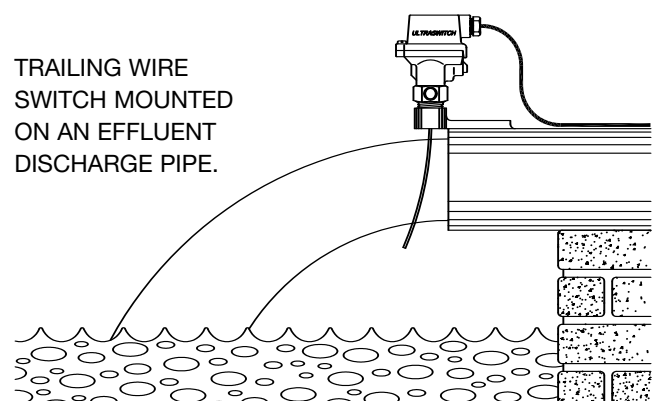
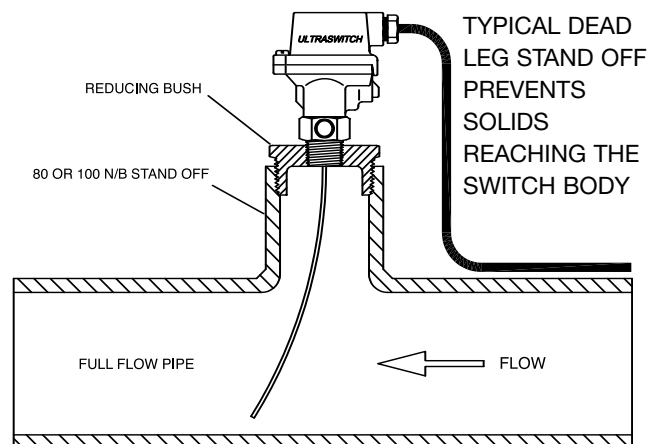

## ELECTRICAL

**All electrical work associated with this flow switch must be carried out by qualified persons only and must be in accordance with the relevant local codes.**

The TW26 flow switch houses a magnetically coupled high current high voltage single pole double throw microswitch. The standard TW26 flow switch is fitted with a 15Amp 500Volt switch suitable for most general control circuit applications. The accompanying table and sketch gives the electrical rating of the switch, and the terminal designations.

Please note that a sensitivity adjusting screw is provided in the switch housing. As supplied this screw is wound fully in, and is set to its least sensitive. Winding this screw anticlockwise, outward will increase the sensitivity of the switch to flow. That is, it will reduce the flow rate required to actuate the switch. This screw should be used for fine-tuning an installation only as the adjustment range is fairly minor. The TW26 flow switch will function with the adjusting screw fully removed.

In exposed locations ensure the lid and cable gland are securely tightened and secondary precautions such as cable drip loops are employed to ensure the ingress protection rating of this switch is achieved.

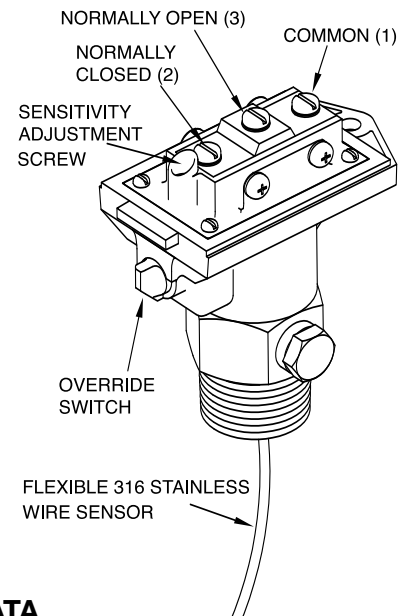

**Please Note:** All of the component parts of the TW26 series trailing wire flow switch are available as spare parts. Spare flexible wire sensor arms should be specified by quoting the required wire length.

### ELECTRICAL DATA

The TW26-S and the TW26-SS models are suitable for general control circuit applications.

Rated Voltage	NON INDUCTIVE LOADS				INDUCTIVE LOADS			
	Resistive load		Lamp Load		Inductive Load		Motor Load	
	NC	NO	NC	NO	NC	NO	NC	NO
125 VAC	15A	3 A	1.5 A	15A	5A	2.5A		
250 VAC	15A	2.5A	1.25A	15A	3A	1.5A		
500 VAC	10A	1.5A	0.75A	6A	1.5A	0.75A		
8 VDC	15A	3 A	1.5 A	15A	5A	2.5A		
14 VDC	15A	3 A	1.5 A	10A	5A	2.5A		
30 VDC	6A	3 A	1.5 A	5A	5A	2.5A		
125 VDC	0.5A	0.5 A	0.5 A	0.05A	0.05A	0.05A		
250 VDC	0.25A	0.25 A	0.25 A	0.03A	0.03A	0.03A		

The TW26 flow switch is normally supplied with a trailing wire pre-cut and terminated to suit the required applications. See accompanying drawing for details of a typical installation. The TW26 flow switch should preferably be installed in horizontal piping, do not use this switch in vertical pipework unless the process liquid is clean and solids free. Do not install the flow switch on the underside of horizontal pipes, or in any orientation where debris may accumulate in the pocket in the switch body and ultimately prevent the switch from operating.

A suitable 25mm (1") B.S.P. female thread socket must be provided on the piping, to fit the flow switch. This may be a tapping saddle or a pipe tee, or a socket welded directly to the piping. Ensure that whatever fitting is used, sufficient clearance is allowed for the free movement of the flexible wire. Normally a clearance to the full inside diameter of the 1" B.S.P. thread (28mm) will be required. The TW26 flow switch can be installed in a one inch B.S.P. socket attached to a short stand off pipe, at 90° to the main pipe. This method increases the sensitivity of the switch to low flows due to the extra leverage against the tip of the wire. It also ensures the body of the switch is kept well out of line of any solids being conveyed in the fluid stream. If it is implemented, please ensure extra clearance is allowed for the free radial movement of the longer wire sensor.

Use thread tape or sealant and tighten the switch into the socket using the spanner flats provided on the switch body. Do not tighten the switch into its socket by twisting the switch body, as damage to the flow switch may result. Align the flow switch squarely to the axis of the pipe, with the direction of flow arrow on the switch body pointing correctly and aligned along the pipe. The TW26 flow switch will not function correctly unless the alignment is correct.

When installing the flow switch in vertically running pipework, note that the sensitivity of the switch will be slightly increased, it will detect lower flows, when flow is downward, and will be slightly decreased when flow is upward. This is due to the effect of gravity and the dead weight of the trailing wire itself. This effect is more noticeable in larger pipes and low flows where long wires may be used.

## MANUAL OVERRIDE

The TW26 flow switch has a built in manual override, located under the cable gland on the end face of the switch. The rotary toggle switch is marked AUTO and ON. In the AUTO position the flow switch responds solely to flow, and the toggle switch has no effect. In the ON position the flow switch is actuated regardless of the state of the actual flow, that is, the switch is turned on. The override feature is handy for testing new installations, commissioning systems and for manually priming pumps or starting diesel pump sets etc. In normal operation the override switch should be rotated fully into the AUTO position. Do not operate the flow switch with the override partly between auto and on, as it may not function correctly.

MADE IN AUSTRALIA BY

**KELCO Engineering Pty Ltd**

ABN 20 002 834 844

Head office and factory

9/9 Powells Road Brookvale 2100 NSW Australia

Phone: +61 2 9905 6425 Fax: +61 2 9905 6420

Email: sales@kelco.com.au Web: www.kelco.com.au

©2008 Kelco Engineering Pty Ltd

**PLEASE NOTE:** Kelco Engineering Pty Ltd reserves the right to change the specification of this product without notice. Kelco Engineering Pty Ltd accepts no liability for personal injury or economic loss as a consequence of the use of this product. All rights reserved copyright Kelco Engineering Pty Ltd © 2008.