

C15 & C20 SERIES INLINE FLOW SWITCH

FEATURES

- STAINLESS STEEL OR BRASS BODY
- CHOICE OF 3 SWITCHING POINTS
- DIESEL AND OIL MODELS AVAILABLE
- CHOICE OF 2 ELECTRICAL MODULES
- VERY HIGH PRESSURE RATING
- LOW HEAD LOSS DESIGN
- FULLY SERVICEABLE
- SPARE PARTS AVAILABLE
- WEATHERPROOF

The C15 & C20 in line flow switches are compact magnetically actuated piston flow switches that switch in response to low fluid flows. They are ideal for many types of pressure boosting and control applications in both hot and cold liquids. They are available with bodies made from brass or 316 stainless steel.



CONSTRUCTION

The C15 / C20 flow switch consists of an electrical switching module that saddles a one-piece metal body. The switches are available in either BSP or NPT threads. The electrical modules fitted to the C15 / C20 flow switches are easily removed without disturbing pipe work, and can be reversed or rotated and positioned to suit tight locations. The switches can handle flows up to 30 Litres per minute (water), and can tolerate static or dynamic pressures to 100 Bars (1470PSI) with a 4 to 1 safety factor.

FLOW SENSITIVITY

Sensitivity to flow depends on liquid viscosity and piston clearance. There are three pistons available to suit the C15 & C20 flow switches. These are designated and marked A, B and C. Switches are normally supplied with one of the three pistons pre-fitted. The table below shows the switch on and switch off flow rates for the three pistons.

Piston Markings	Switching Point on a Slowly Rising Flow in Litres per Minute	Switching Point on a Slowly Reducing Flow in Litres per Minute	Electrical Response Time in Seconds
A	0.140	0.065	0.4
B	0.570	0.370	0.3
C	1.70	1.33	0.2

Note: The data shown in the table above refers to water at ambient temperature as the test medium. Increasing fluid viscosity will decrease the switch on points. Decreasing the fluid viscosity will proportionally increase the switch on points.

INSTALLATION

The flow switches can be positioned in any orientation in pipework. In vertical piping, flow can be either upward or downward through the switch with very little difference in sensitivity. This flow switch is suitable for use with hot or cold liquids up to 90°C. Systems can be steam sterilized at 100°C for short periods without damaging the switch.

HAZARDOUS APPLICATIONS

The -B version of the C15 / C20 flow switches can be used in hazardous areas. They are classed as simple devices as they do not contain components capable of storing or producing an electric charge. As simple devices the switches can be used in hazardous applications provided they are isolated by an intrinsically safe barrier.



AUSTRALIAN MADE

TECHNICAL DATA

GENERAL LAYOUT

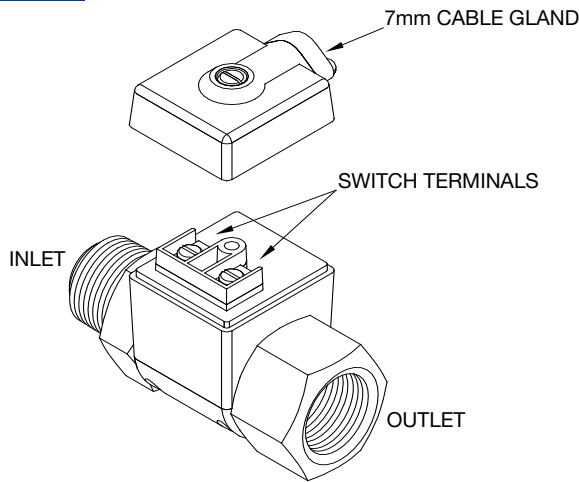

DIMENSIONS

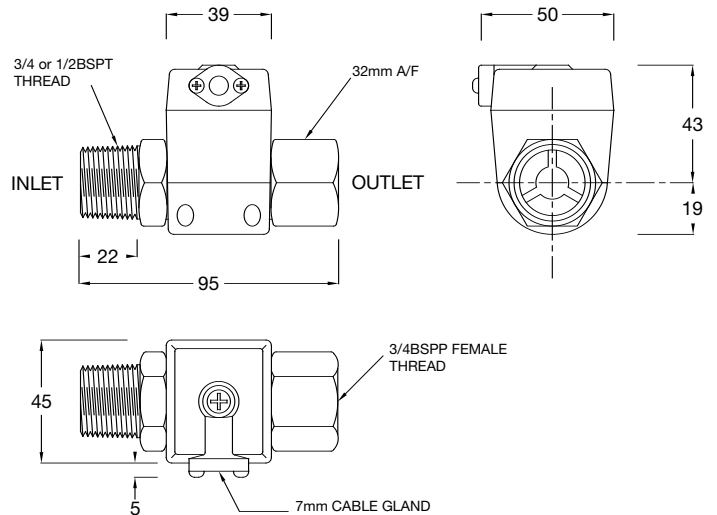

ELECTRICAL DATA

Sensor Model	Module Type	Contact Configuration	Switched Power Maximum	Switched Voltage Maximum	Switched Current Resistive AC (rms)	Inductive Loads (Power Factor 0.4)	Typical Application
B	Dry Reed Switch	S.P.S.T Normally Open	40Watts	240VAC 200VDC	1 Amp Maximum	Not Suitable	PLC Telemetry and Relay Logic circuits
R	Solid State Relay (Triac)	S.P.S.T Normally Open	1.1kW	5 to 240V AC	10mA Minimum 5 Amps Maximum	5 Amps at 240V	AC control circuits and direct motor control

Note: The switched power of the C20-R module given above refers to a switch operating in a water pipe system at ambient temperature. In hot water applications the switched power must be proportionally reduced to avoid overheating the Triac. At the top operating temperature of 90°C the switched power must not exceed 375 Watts. The C20-B modules do not require de-rating at elevated temperatures.

HEAD LOSS VERSUS FLOW RATE

Table based on test results from water only, See Flow sensitivity for other fluids.

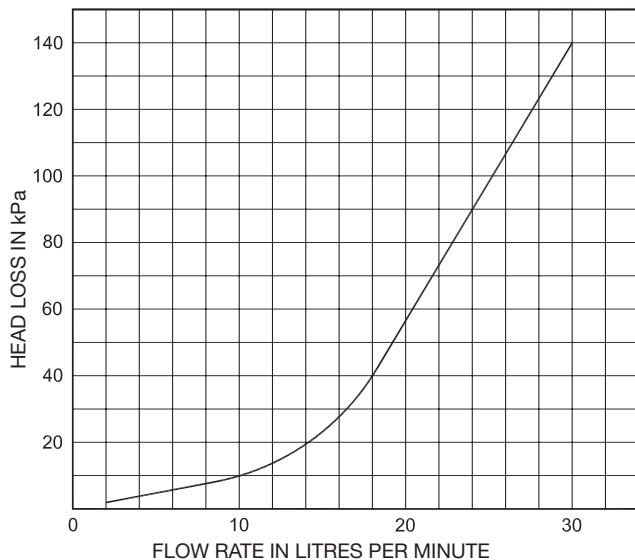

ORDERING

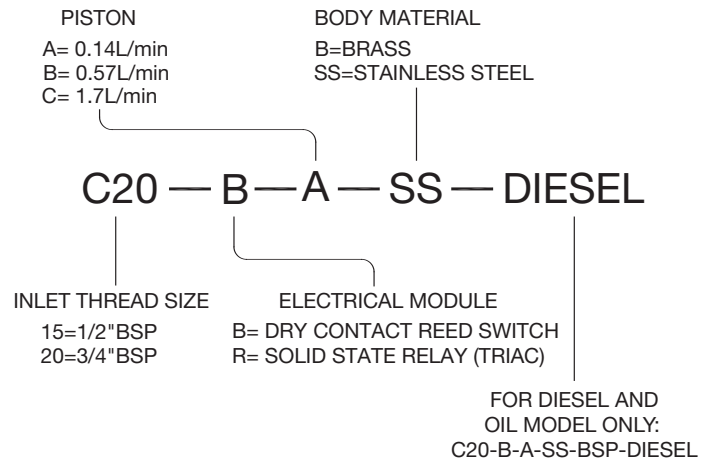

MADE IN AUSTRALIA BY

KELCO Engineering Pty Ltd

ABN 20 002 834 844

Head office and factory

9/9 Powells Road Brookvale 2100 NSW Australia

Phone: +61 2 9905 6425 Fax: +61 2 9905 6420

Email: sales@kelco.com.au Web: www.kelco.com.au

©2008 Kelco Engineering Pty Ltd

PLEASE NOTE: Kelco Engineering Pty Ltd reserves the right to change the specification of this product without notice. Kelco Engineering Pty Ltd accepts no liability for personal injury or economic loss as a consequence of the use of this product. All rights reserved copyright Kelco Engineering Pty Ltd © 2008.