

INSTALLATION AND OPERATING OF F27 TIME DELAY FLOW SWITCH

The F27 flow switch requires both electrical and mechanical fitting. Installation or servicing of these switches should only be carried out by competent qualified personnel familiar with hydraulics, pump fitting and with electrical control circuitry.

INSTALLATION

A suitable location should be selected for the F27 in either the suction or delivery pipework of the pump. The switch should be installed in a location that is away from both vibration and heat, preferably out of direct exposure to the weather and above any flood level. A 1" BSP or larger socket must be provided in the pipework to fit the switch. The socket should be located on the topside of a horizontal section of the pipe with at least 5 diameters of straight pipe either side of the F27. Under no circumstances mount the F27 under the pipe or close to valves, tees, bends or any other object likely to cause turbulence in the flow. The F27 can be mounted in vertical pipework if required.

TYPICAL RURAL OR INDUSTRIAL PUMP INSTALLATION

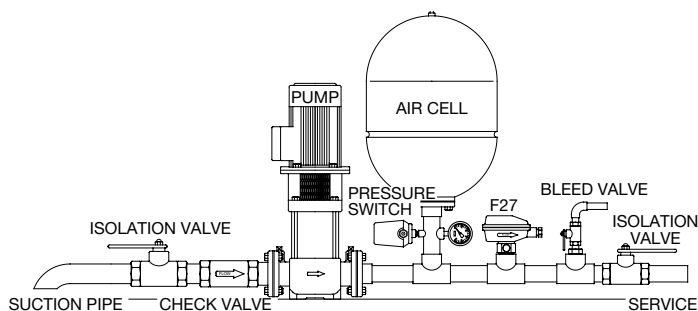

TYPICAL INSTALLATION WITH AN F27 CONTROLLING A VERTICAL MULTI-STAGE PUMP

In most installations the paddle of the flow switch will need to be trimmed to suit the specific pipe in which the unit is to be installed. The paddle of the flow switch needs a force of around 15 to 20 grams acting on it from the flow in order to operate correctly. High velocity flow can generate high forces and damage or break the paddle. As a general guide the paddle of the flow switch should extend to the centre line of the pipe. The paddle would not normally be left longer than this unless the expected flow velocity was very low. Cut the paddle so it extends to the centre line of the pipe when screwed into its socket. Apply a suitable thread sealant and screw the flow switch into the socket using the spanner flats provided. Do not twist the body of the F27 or use it to screw the unit into the socket, as to do so may damage the switch housing. When properly installed the flow switch should be square to the line of the pipe with the flow arrow on the switch body parallel to the line of flow. In addition there should be a gap of at least 3mm between the top of the 1" BSP thread and the under edge of the spanner hexagon. Under no circumstances should the thread be allowed to bottom out in its socket as to do so places the thread in tension and may result in the flow switch housing cracking under pressure.

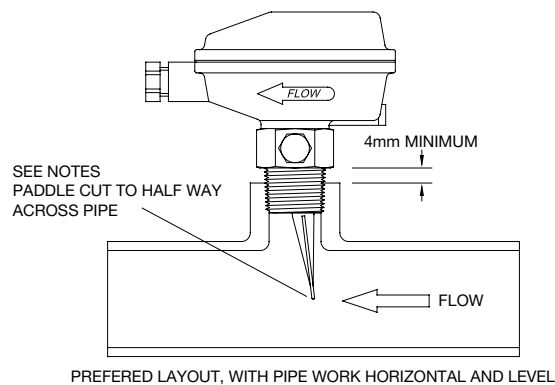

F27 INSTALLED IN A PIPE TEE

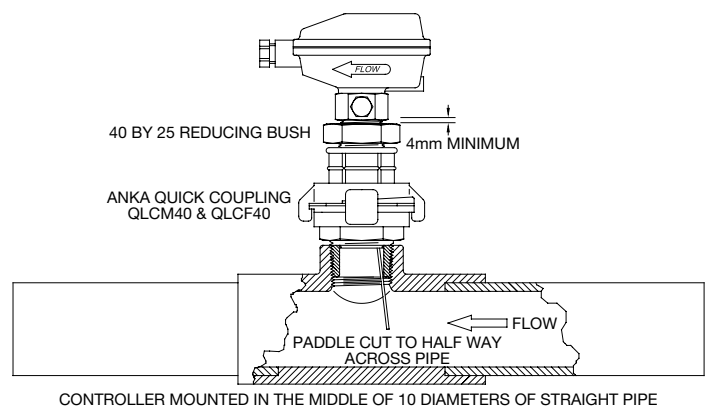

F27 INSTALLED IN A QUICK RELEASE COUPLING

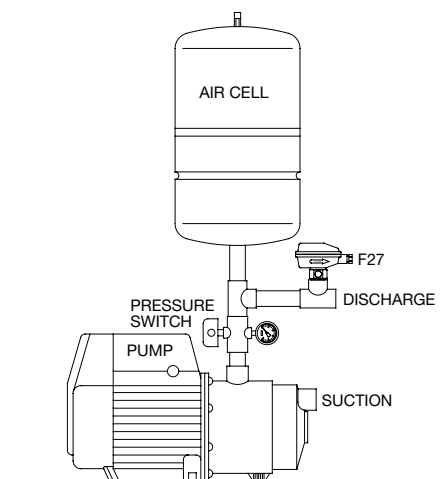

DOMESTIC PRESSURE SYSTEM PROTECTED BY AN F27

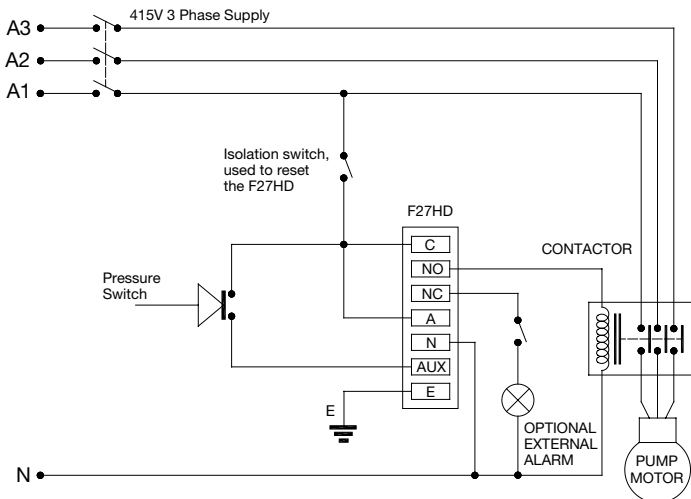

WIRING DIAGRAM FOR A 3 PHASE PUMP

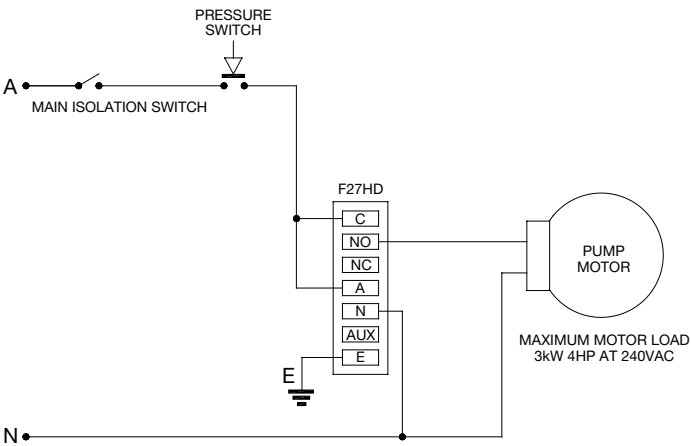

TYPICAL SINGLE PHASE PRESSURE SYSTEM WIRING DIAGRAM

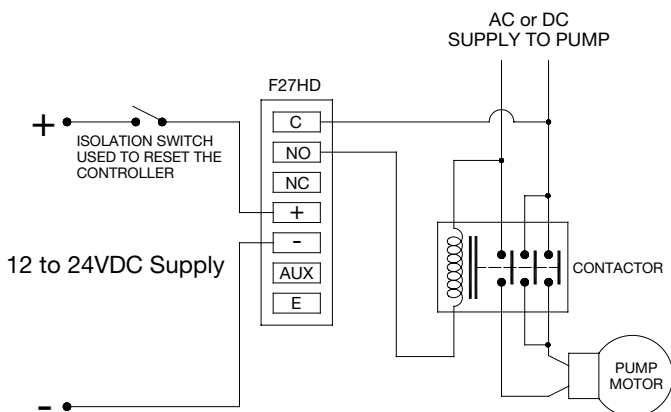

Note
Terminals "C, NO and NC" are voltage free contacts

F27-DC WIRING DIAGRAM

ELECTRICAL

The F27 flow switch requires a stable supply voltage in order to operate correctly. Pay particular attention to cable sizes, and ensure cables are adequate for the specific pump motor load. This is particularly relevant where long cable runs are to be used in the installation. If the voltage drop associated with the pump motor starting is excessive the F27 will reset, and may cause the pump to jog. Jogging can snap a pump shaft very quickly, so please take all precautions to ensure the voltage supply to the F27 is stable and adequate for the job. Supply voltage must be within the limits set out in the table below.

VOLTAGE RATING

MODEL	MAXIMUM SUPPLY VOLTAGE	MINIMUM SUPPLY VOLTAGE
F27-240HD F27-240	260V AC	160V AC
F27-24HD F27-24	28V AC	18V AC
F27-DC	24V DC	9V DC

IMPORTANT NOTES:

Never connect a DC load across the normally open terminals of the F27HD. These flow switches are only suitable for AC applications. The F27HD models are designed for direct motor control and do not have voltage free contacts. To operate properly all F27HD models require a minimum load of 10mA impressed across the normally open terminals. The small leakage current across the normally open terminals means the F27HD flow switches are not suitable for driving small loads such as low wattage relays or electronic timers. For such applications use a standard F27-240 or F27-24 flow switch. The F27-DC can be used in AC or DC applications. Its relay contacts are voltage free.

The F27-240HD and F27-24HD flow switches incorporate a solid state drive to control a pump connected to their common and normally open output terminals. The solid state drive enables very large pump motors to be directly controlled, without the need for an interposing contactor. The maximum size motor that can be controlled directly by the F27HD flow switches is 3.75kW 5HP. At 240VAC the maximum recommended continuous current load controlled by the F27HD must not exceed 16 Amps. The maximum motor starting current should not exceed 60 Amps.

F27-DC

The F27-DC is essentially a control device that incorporates an S.P.D.T. relay as its output. The F27-DC does have the capacity to directly control small AC pump motors up to 0.75kW 1HP. For all DC motor load applications, an interposing contactor must be used between the F27-DC and the load.

All F27 flow switches have a single set of normally closed voltage free terminals, marked "C" and "NC", with a 16Amp 240V resistive rating. These contacts can be used to control an external alarm or loss of flow warning light if required.

Several examples of typical wiring arrangements are provided on this installation sheet. The circuits provided are intended as a guide only to show the most common ways to connect an F27 flow switch.

CONTROL LAYOUT AND FUNCTIONS

- 1** marked “START-UP TIMER”, adjustable in steps from 0 to 180 seconds, runs once only each time the F27 is powered up or reset.
 - 2** marked “RUN-ON TIMER”, adjustable in steps from 0 to 300 seconds. Can be used to prevent the pump from cutting out on minor flow interruptions as caused by air bubbles in the piping. Can also be used to run the pump on and pressurise pipes or to pressurise an air cell.
 - 3** marked “PADDLE”, Paddle status LED turns green whenever the paddle is pushed forward by flow. Slowly blinks red when the F27 is in standby mode with the paddle off, to indicate the power is on and the pump is off but is being monitored.
 - 4** marked “TIMERS”, This LED turns green when the start-up timer is running, which occurs each time the system is powered up. It also indicates when the run-on timer is running by turning red. When setting up an F27 this LED is essential because it allows you to observe exactly how long the timers run after the paddle has been pushed into the on position by the flow. It allows the timer dials to then be correctly set to slightly longer than the time it takes for the paddle LED to come on.
- C** Common output terminal, Power is normally looped into the common terminal from the supply active.
- NO** Normally open terminal, a switch wire is normally run from this terminal directly to the pump motor.
- NC** Normally closed terminal, usually left unused, but can be connected to an external alarm or warning light if required.
- A** Active terminal connects to the supply active, usually via an isolation switch.
- N** Neutral terminal connects to the supply neutral.
- AUX** Not used on F27 flow switches, it is simply an isolated terminal.
- E** Earth terminal, isolated binding post for termination of earth wires.

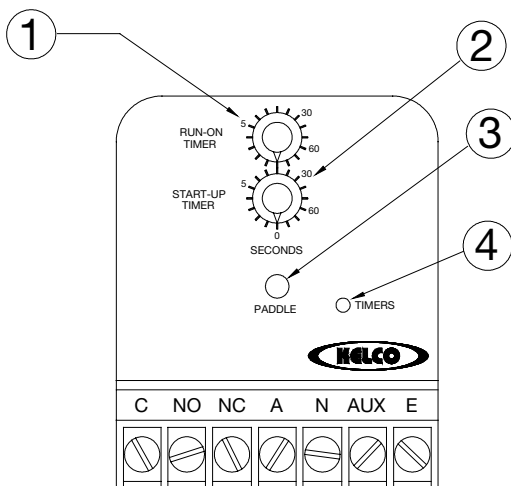

CONTROL LAYOUT

FUNCTIONS OF THE INDICATOR LIGHTS

PADDLE LIGHT (3)	FUNCTION
GREEN	Indicates that the paddle is in the flow position. Normally off, this light turns green as soon as flow pushes the paddle forward. The pump will be on whenever this light is green.
SLOW RED PULSE	Blinks red every 2 seconds to indicate power is on. This light will blink red whenever the power is on but the pump is off.

TIMER LIGHT (4)	FUNCTION
GREEN	Provided the start-up timer is not set to zero, this light indicates the start-up timer is running, only comes on when the F27 is first powered up. The pump will run while ever this light is on.
RED	Turns red to indicate the run-on timer is running. Can only come on after the start-up timer has timed out. Provided the run-on timer is not set to zero, this light will turn on red whenever the paddle swings to the off position, indicating flow has stopped.

TIMER SETTINGS

Time delay adjustment is by means of two 16 position rotary switches. The time delays are programmed into the F27 to give the rotary switches the following time delays.

TIMER	DELAY IN SECONDS
Start-up Timer	0, 1, 2, 3, 4, 5, 10, 15, 20, 25, 30, 40, 50, 60, 120, 180
Run-on Timer	0, 1, 2, 3, 4, 5, 10, 15, 20, 25, 30, 40, 50, 60, 180, 300

ADJUSTING TIMER SETTINGS

When adjusting the timer settings, the power to the F27 must be reset, that is, it must be turned off for a minimum of 1 second and then turned on again, before the changes will take effect. This applies to all the F27 models.

BASIC FLOW SWITCH FUNCTION

The F27 pump controllers have two independent timers and are individually adjustable in steps. With both timer dials set to zero, the controllers behave like a basic flow switch, they will respond solely to paddle movement.

START-UP TIMER

Setting the start-up timer will override the off state of the flow switch, so that when power is applied, your pump will start, and will run for whatever time you have set the dial to. The small green timer LED will be on while the timer is running, and normally flow will push the paddle on while the timer is running. This is indicated by the paddle LED turning on green in response to flow. When correctly set, the start-up timer should be set to slightly longer than the time it takes for the main green paddle LED to come on.

RUN-ON TIMER

The run-on timer can be set to suit the specific application, for example it can be set to several minutes to pressurise long pipe runs, or it can be set to several seconds to simply allow the pump to ignore minor fluctuations in flow. It can also be left set to zero if not required.

The main timer and the run-on timer function independently of each other and are totally flexible. For example, you can set the main timer to 3 seconds, to get a pump started, and the run on timer to 2 minutes to run a pump on and pressurise a pipe system or air cell. Alternately you could set the main timer to 3 minutes to allow a bore pump with a self draining riser time to prime its riser, and you can also set the run on timer to 2 or 3 minutes to pressurise a feed line to a remote stock trough, long after the main flow has reduced to a trickle.

PRESSURE SYSTEMS

The F27 flow switch can be used to protect a conventional pressure start pressure stop pump from running dry on loss of flow. In a conventional pressure system, a pressure switch turns the pump on when the pressure drops, and switches it off when the pressure rises. All such systems have one basic flaw, if they run out of water for any reason, the lack of pressure will hold the pressure switch on and keep the pump running. The result is usually severe damage to the pump. To protect a pressure pump in such a situation, connect the F27 flow switch to the pressure switch and pump, as set out in the accompanying wiring diagram. Note that with this arrangement the pressure switch will control the F27, and in turn the F27 will control the pump. The F27 will have minimal effect on the normal operation of the pressure system. The pump will switch on on a falling pressure and switch off on a rising pressure as normal. If however the pump runs dry the loss of flow will be detected by the F27, which will respond by running its run on timer for whatever time you have set it to, and at the end of the timeout if flow has not been re-established, the pump will be shut down.

SENSITIVITY ADJUSTMENT

A sensitivity adjusting screw is provided for fine-tuning the F27. Under the end of the switch housing is a hex-headed plug that covers the adjusting screw. Remove the plug and using a broad-bladed screwdriver wind the adjusting screw anticlockwise to increase the sensitivity (reduce the flow rate needed to actuate the paddle). As supplied, the screw is wound fully in and the controller set to its least sensitive. The maximum sensitivity is reached with the screw wound out to a point where the hex dust cover can still be refitted. Normally the sensitivity screw should be left fully in. If the paddle has been trimmed too short, the effect can be compensated for by winding the sensitivity screw out a few turns.

MADE IN AUSTRALIA BY

KELCO

KELCO ENGINEERING Pty Ltd ABN 20 002 834 844
Head Office and Factory: 9/9 Powells Road BROOKVALE 2100 AUSTRALIA
Postal Address PO Box 496 BROOKVALE NSW 2100
Phone: (61) 2 99056425 Fax: (61) 2 99056420
Email: sales@kelco.com.au URL www.kelco.com.au

PLEASE NOTE: Kelco Engineering Pty Ltd reserves the right to change the specification of this product without notice. Kelco Engineering Pty Ltd accepts no liability for personal injury or economic loss as a consequence of the use of this product. All rights reserved copyright Kelco Engineering Pty Ltd © 2008