

F30 PUMP CONTROLLER ON TANK FILLING WITH OPEN DISCHARGE 415V 3 PHASE PUMP

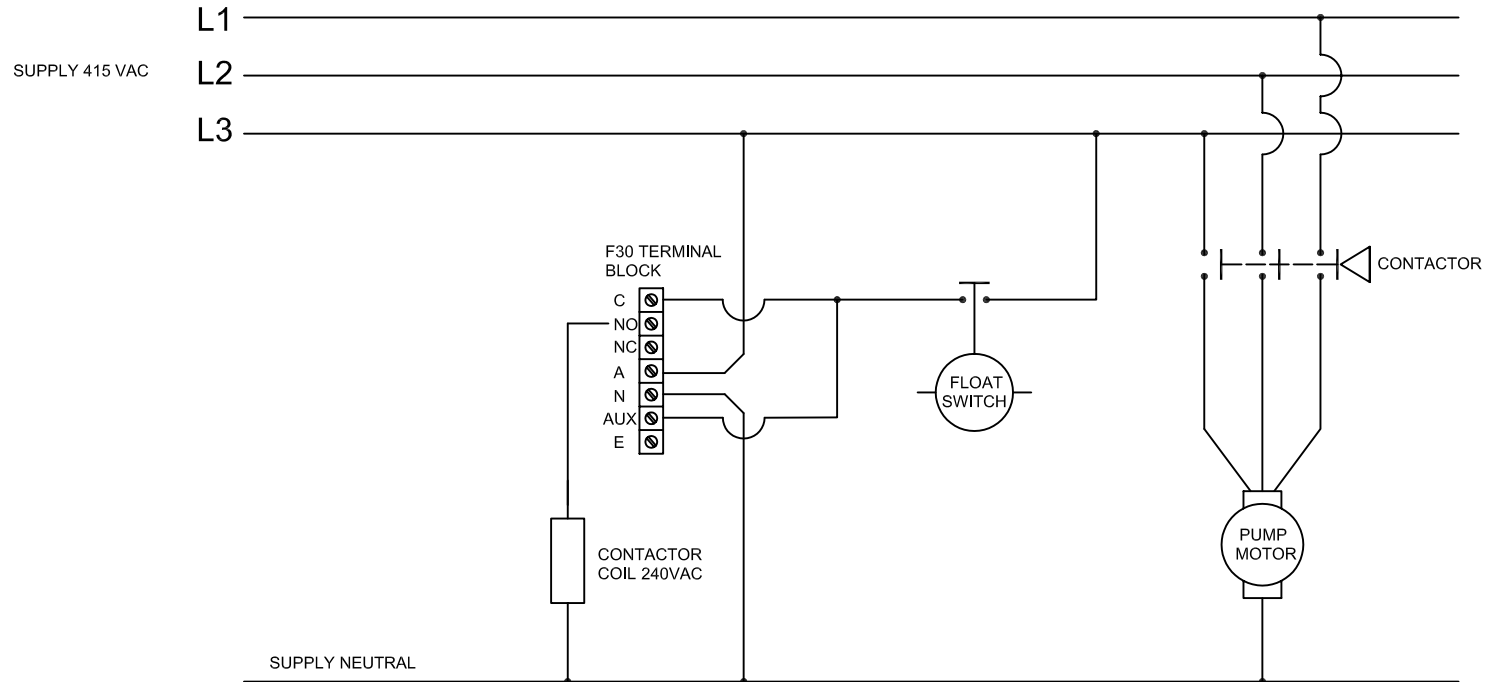

NOTE

THE F30 CAN DIRECTLY DRIVE SINGLE PHASE PUMP MOTORS UP TO 0.75kW (1 HP). FOR LARGER MOTORS AND 3 PHASE MOTORS USE THE F30 TO DRIVE A CONTACTOR COIL WITH THE CONTACTOR DRIVING THE PUMP, AS SHOWN ABOVE.

NOTE

THE F30 REQUIRES A CONTINUOUS SUPPLY TO ITS ACTIVE / NEUTRAL TERMINALS.

WHEN THE FLOAT SWITCH CLOSES IT PUTS POWER ONTO THE AUX TERMINAL AND ONTO THE "C" COMMON TERMINAL. THE PUMP STARTS AND RUNS WHILE EVER THE FLOAT SWITCH REMAINS CLOSED. WHEN THE TANK IS FULL THE FLOAT SWITCH OPENS TAKING POWER OFF THE "C" TERMINAL AND STOPPING THE PUMP. AT THIS POINT THE F30 WILL REMAIN ON RUNNING ON ITS RUN ON TIMER. AT THE END OF THE RUN ON TIME THE F30 REVERTS TO STANDBY MODE WITH ITS RED LIGHT SLOWLY BLINKING.

DRY RUN PROTECTION

IF THE SYSTEM IS RUNNING AND THE TANK IS FILLING AND THE PUMP RUNS DRY THE F30 PADDLE WILL SWING TO THE OFF POSITION AND THE RUN ON TIMER WILL START. WHEN THE RUN ON TIMER TIMES OUT THE MICROPROCESSOR LOOKS AT THE STATE OF THE PADDLE, FINDS IT OFF AND STOPS THE PUMP. IN SPITE OF THE FLOAT SWITCH BEING ON. IN THIS STATE THE RED LIGHT ON THE F30 WILL FLASH RAPIDLY INDICATING DRY RUN, AND THE SYSTEM WILL NOT RESTART UNTIL THE POWER TO THE WHOLE SYSTEM IS RESET.