

## LC20 MODULAR LEVEL SWITCH SYSTEM



### FEATURES

- VERSATILE MULTIPOINT LEVEL SENSORS
- FOR TANK GAUGING & LEVEL CONTROL
- SUITS PVC OR STAINLESS SYSTEMS
- SERVICEABLE AND EXPANDABLE
- SIMPLE AND RELIABLE
- IP67 WEATHERPROOF
- EASILY ADJUSTED

*The LC20 modular level switches enable users to easily build sophisticated systems to monitor liquid levels and to control alarms and pumps. The system is very flexible and can be used with PVC, stainless steel or copper tubes and can be easily adjusted, added to or serviced.*

### DESCRIPTION

A number of compact highly weatherproof sensing heads are positioned along a vertical riser pipe that is attached to the side of a tank. The riser pipe is made from a length of standard 20mm PVC or 1 inch stainless steel or copper tube. Liquid level rising and falling in the tank and in the riser pipe, carries a small magnetic float through the sensor heads and provides a series of switching points that can be used for a multitude of level control and sensing applications. Typical uses include water treatment equipment, beverage, cosmetics and pharmaceutical manufacture, chemical metering systems, water features and a vast variety of mechanical services and process control applications.

A typical system comprises a tank with an externally mounted balance pipe, or riser pipe alongside. The riser pipe is connected to the base of the tank and is constructed from standard pipe and fittings. Liquid level in the tank maintains an equal level in the riser pipe. As the level of liquid in the tank changes so does the level in the adjacent riser. A small float containing a magnet rides up and down within the riser pipe, and is carried through the sensor heads, causing them to sequentially switch.

### LC20 SENSOR HEADS

The LC20 sensor heads are available as normally open or normally closed switches. Both types can be supplied with dry reed switch contacts or with built-in Triacs for control of moderate AC loads. The sensor heads clamp around standard tube or pipe, and can be easily removed or repositioned if required. They are sized to fit standard 20mm PVC or ABS pipe and a spacer is supplied with each sensor to adapt it to fit 25.4mm (1") diameter metal or glass tubing.

Each sensor head provides a single switching point, either on or off as the system's float passes through it. Once actuated, a level change of 5mm, either up or down will cause the sensor to change state. LC20 heads are ideal for relay control, for making and breaking latched relay logic circuits and for PLC control. Any number of sensors can be stacked along a riser pipe, but typical systems normally consist of 2, 4 or 6 heads. For accurate tank level-gauging sensors can be stacked close together along the riser pipe. The minimum distance between sensors is 40mm. The maximum distance is unlimited.

### ELECTRICAL OPTIONS

For PLC, relay logic and telemetry circuits the model LC20-B-NO provides a single set of normally open voltage free contacts in the form of a dry contact reed switch. For moderate current AC applications, a high power model designated LC20-R-NO; containing a Triac solid-state relay is also available. For reverse acting applications, the LC20-B-NC and LC20-R-NC models provide a single set of normally closed contacts.



**AUSTRALIAN MADE**

# TECHNICAL DATA

## SENSOR DETAILS

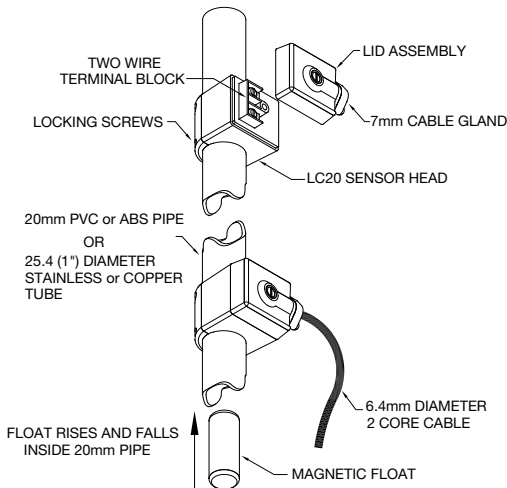

## FLOAT

A magnetic float is supplied with each LC20 sensor head. The float is made from polypropylene and is sized to easily fit inside 20mm Class 18 PVC pipe. The float is buoyant enough to operate in liquids with a specific gravity of >0.80, and in pressure vessel applications can tolerate pressures to 10 Bars (150 PSI). The Float has an eyelet in it's top face so a cord can be attached for testing systems and for commissioning.

## TYPICAL APPLICATIONS

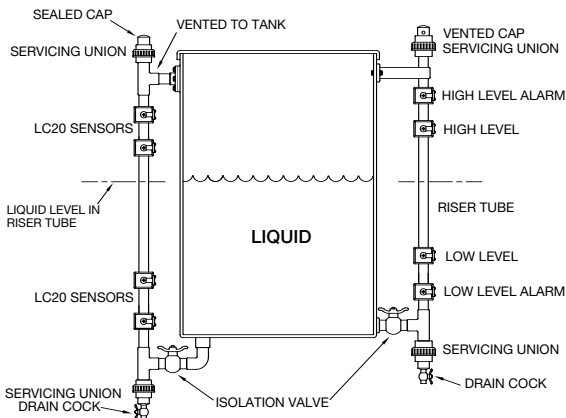

## DIMENSIONS

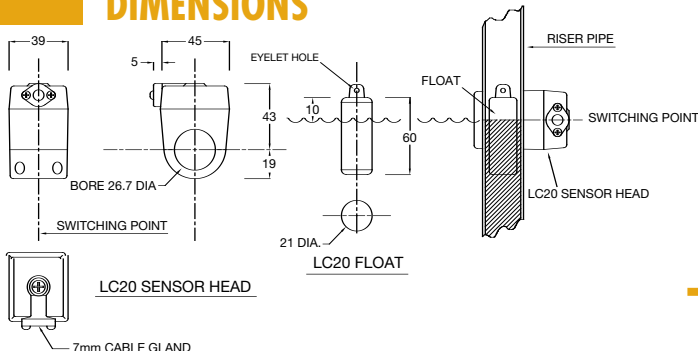

## STAINLESS STEEL TUBE SYSTEMS

The LC20 system operates magnetically and will only work in tube and pipe systems that are magnetically transparent. A riser tube can be constructed from essentially any material that is of the correct diameter and bore and is non magnetic. For example 1" diameter brass or copper tube will work perfectly, as will 1" diameter glass tube. Some grades of stainless and some special corrosion resistant alloys will attract a magnet and are therefore unsuitable. Generally, grade 304 and grade 316 stainless steel is non magnetic and will work perfectly with the LC20 system.

## ELECTRICAL DATA

Sensor Model	Module Type	Contact Configuration	Switched Power Maximum	Switched Voltage Maximum	Switched Current Resistive AC (rms) Maximum	Inductive Loads (Power Factor 0.4)	Typical Application
LC20-B	Dry Reed Switch	S.P.S.T NO or NC	40Watts	240VAC 200VDC	1 Amp	Not Suitable	PLC Telemetry and Relay Logic circuits
LC20-R	Solid State Relay (Triac)	S.P.S.T NO or NC	750Watts	5 to 240V AC only	4 Amps	4 Amps at 240V	AC control circuits and direct pump control

**Note:** The switched power of the LC20-R module given above refers to a sensor operating on a metal riser pipe at ambient temperature. In hot liquid applications the switched power must be proportionally reduced to avoid overheating the Triac. At the top operating temperature of 90°C the switched power must not exceed 375 Watts. The LC20-B sensor heads do not require de-rating at elevated temperatures.

## OPERATING ENVIRONMENT

The LC20 level sensing system is suitable for use with most liquids of the correct specific gravity that can be contained within the system's riser pipe. This includes acids, alkalis, sea water, brine solutions, chlorinated solutions and oils. When used with PVC or ABS riser pipe, liquid temperature should never exceed 60°C. In stainless and copper tube systems, the LC20 sensor heads can be operated at temperatures of up to 90°C continuously. For short periods, such as for system sterilization the sensors and float will tolerate temperatures to 100°C. The system is suitable for use in pressurized vessels up to 10 Bars (150PSI). Do not use the LC20 level sensing system with isomorphous solutions or with liquids containing material that coats out, cakes up, or with liquids that contain solids of any appreciable size. Any material in the liquid that impedes the free movement of the float may cause malfunctions. Where solids may be present, such as in waste and effluent applications, it is generally possible to install a strainer at the base of the riser pipe to prevent ingress of solids.

## HAZARDOUS LOCATIONS

The LC20 level sensing system can be used in hazardous areas. The sensor heads are classed as simple devices as they do not contain components capable of storing or producing an electric charge. As simple devices the LC20 sensors can be used in hazardous applications provided the heads are isolated by an intrinsically safe barrier, a zener barrier.

## ORDERING

Each kit consists of one sensor head and one float. In addition to the kits, individual components are also available at all times to allow for expansion of systems or for spare parts.

### LC20 - B - NO

SWITCH TYPE  
B = DRY CONTACT REED SWITCH  
R = SOLID STATE RELAY (TRIAC)

SWITCH FUNCTION  
NO = NORMALLY OPEN  
NC = NORMALLY CLOSED

MADE IN AUSTRALIA BY

**KELCO Engineering Pty Ltd**

ABN 20 002 834 844

Head office and factory

9/9 Powells Road Brookvale 2100 NSW Australia

Phone: +61 2 9905 6425 Fax: +61 2 9905 6420

Email: sales@kelco.com.au Web: www.kelco.com.au

©2008 Kelco Engineering Pty Ltd

**PLEASE NOTE:** Kelco Engineering Pty Ltd reserves the right to change the specification of this product without notice. Kelco Engineering Pty Ltd accepts no liability for personal injury or economic loss as a consequence of the use of this product. All rights reserved copyright Kelco Engineering Pty Ltd © 2008.