

## MF20 MICRO FLOW SWITCHES



### FEATURES

- DETECTS FLOWS OF LESS THAN 350mL /Hour
- SUITS TUBES & PIPES 6 to 20mm (1/4" to 3/4") DIA.
- NO METAL PARTS IN CONTACT WITH LIQUIDS
- SUITS PULSED OR CONTINUOUS FLOWS
- 18 BAR (260 PSI) PRESSURE RATING
- STABLE ELECTRICAL RESPONSE
- VERY HIGH FLOW THROUGH
- MANY OPTIONS AVAILABLE
- VERY LOW HEAD LOSS
- VERTICAL MOUNTING
- EASY TO INSTALL

### APPLICATIONS

- CONTROL FOR BACKUP DOSING PUMPS
- CHEMICAL METERING PUMP CONTROL
- CHEMICAL INJECTION POINT STATUS
- VAPOUR & GAS FLOW DETECTION
- LABORATORY APPLICATIONS
- LOSS OF PRIME DETECTION
- BATCH CONTROL

### DESCRIPTION

The MF20 micro flow switch is a super sensitive version of our popular P20 in line flow switch. The MF20 is a very simple and reliable mechanical flow switch that can detect extremely low flows; the switch can detect either continuous or pulsed flows. Typical applications include monitoring chemical metering pumps to ensure they are delivering flow, in water treatment, cooling towers and in a multitude of industrial processes. The MF20 flow switch gives a simple on or off response to liquid flow. There are no metal parts in contact with liquids within the switch, so the MF20 is ideal for use in aggressive media such as acids and alkalis and many chemical solutions. The standard switch is supplied complete with tube flare fittings, for 3 popular tube sizes, and a set of pipe spigots and unions, for direct fitting into 15NB PVC or ABS pipe work. In addition, a number of electrical options are available. These include electrical modules with single and multiple reed switches, relays with various coil voltages, and solid-state switches.

### OPERATING PRINCIPLE

The body of the MF20 flow switch houses a fluted piston. Any flow, either pulsed or continuous, causes the piston to be lifted up within the switch body to a point where the liquid can pass over the piston and out of the top of the switch. The piston contains a magnet that actuates a reed switch and this provides the switching output. When flow stops, the piston sinks due to gravity, thus moving the magnet within away from the reed switch. No metal parts are in contact with the process liquid, and the simple gravity return system provides an exceptionally reliable corrosion proof mechanism. The sensitivity of the flow switch is determined by the viscosity of the fluid and by the clearance between the piston and the switch body. Three pistons are supplied with each MF20 flow switch, with accurate and predictable switch points ranging from 0.32 litres per hour to 12.8 litres per hour. The MF20 flow switch must be mounted vertically with flow upward through the switch body. The switch can be mounted directly on the suction or discharge valve of a metering pump.

### CONSTRUCTION

The Micro flow MF20 flow switch is made from glass-reinforced polypropylene with EPDM O-ring seals and PVC spigots. These are the only materials that come in contact with liquids passing through the switch. A high power rare earth magnet operating through the solid body of the switch actuates the MF20 electrically. The electrical housing is weatherproof to IP67, and is supplied with an integral 20mm cable gland, for conduit or cable entry. The electrical circuit boards used in the switch are interchangeable, and all of the parts of the MF20 flow switch are available as spare parts.



**AUSTRALIAN MADE**

# TECHNICAL DATA

## FLOW SENSITIVITY AND RESPONSE TIME

Sensitivity to fluid flow is a function of liquid viscosity and piston clearance. There are 3 pistons available to suit the MF20 flow switch. Each piston has a distinct switching point. The pistons are designated and marked A, B and C. The "A" piston is fitted to the MF20 flow switch as standard. The optional "B" and "C" pistons are also supplied packed in with each switch. The following table sets out the performance parameters of the 3 pistons. The data is based on testing with water at 15°C as the test medium, and is accurate to +/-10%. Changes in liquid viscosity or temperature will affect the switching point. Increases in viscosity will proportionally decrease the flow rate required to actuate the switch, and will proportionally increase the response time. Decreasing viscosity will proportionally increase the flow required to actuate the switch, and will proportionally decrease the response time.

**Note:** In pulsed flow applications where no pulse dampener is installed, and the pulse frequency is less than the electrical response time, the MF20 flow switch may respond with a train of on / off pulses rather than with a continuous on signal.

Piston Markings and Designation	Switching Point on a Rising Flow in Litres per Hour	Switching Point on a Reducing Flow in Litres Per Hour	Electrical Response Time in Seconds on Cessation of Flow
<b>A</b>	<b>0.32</b>	<b>0.30</b>	<b>4</b>
<b>B</b>	<b>3.10</b>	<b>3.05</b>	<b>3</b>
<b>C</b>	<b>12.80</b>	<b>12.6</b>	<b>2</b>

**Please Note:** The type "A" piston is supplied as standard fitted to each switch, unless otherwise specified. The B & C pistons are included packed in with each switch.

The graph shows the dynamic head loss across the MF20 flow switches. The data refers to water at 15°C as the test medium.

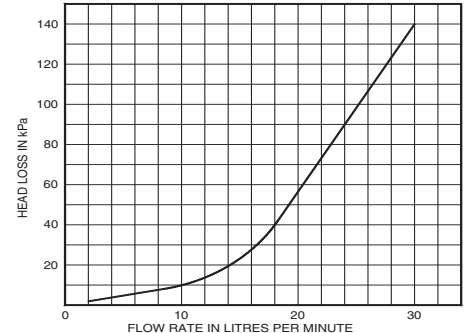

## DIMENSIONS

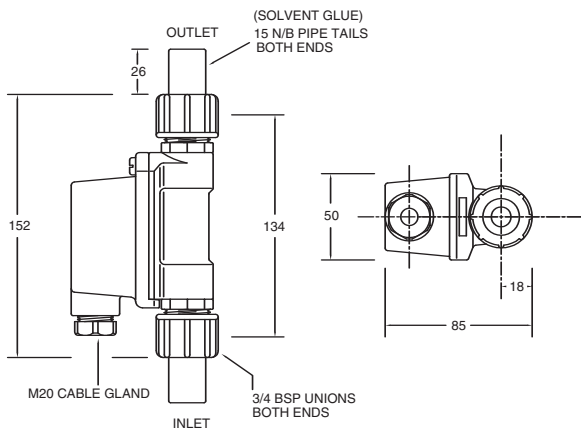

## OPERATING ENVIRONMENT

Maximum Recommended Operating Pressure (Static or Dynamic) at Ambient Temperature	1800 kPa (260 P.S.I.)
Minimum Burst Pressure at Ambient Temperature	9700 kPa (1400 P.S.I.)
Maximum Liquid Temperature (Standard MF20 Switch)	80 Degrees C at a pressure 1 bar absolute, see note below
Minimum Liquid Temperature (Standard MF20 Switch)	-30°C
Maximum Recommended Continuous Flow Rate (Water)	25 Litres per Minute (Head loss across the switch <100kPa at 25L/min)
Liquid Ph range	1 to 14
Ingress Protection Rating (Weatherproof Rating)	IP67

**Note:** Temperature for the maximum operating pressure shown in the above operating environment table is 15°C. In the interest of safety, maximum operating pressure must be de-rated linearly in direct proportion to temperature increase, to a maximum pressure of 1 bar absolute at 80 degrees Centigrade. In other words only use this switch at elevated temperatures in non pressurised systems that are totally open to atmosphere in all circumstances and under all conditions.

## ELECTRICAL DATA

The MF20 in line flow switch is available in a variety of electrical configurations, to suit specific applications. The model numbers and details of these options are outlined in the table below.

Switch Model	Module Type	Contact Configuration	Switched Power Maximum	Switched Voltage Maximum	Switched Current Resistive AC (rms) Maximum	Inductive Loads (Power Factor 0.4)	Typical Application
MF20-B	Dry Reed Switch	S.P.S.T. N.O	40W	240V AC 200V DC	1A	Not Suitable	PLC and General Control Circuits
MF20-C	Dry Reed Switch	S.P.D.T.	40W	240V AC 200V DC	1A	Not Suitable	PLC and General Control Circuits
MF20-R	Solid State Relay (Triac)	S.P.S.T. N.O	750W	2 to 240V AC	4A Continuous (Spike to 16A)	4A at 240V AC	AC Control Circuits and AC Motor Control to 1 HP
MF20-A240	Standard Relay 240V AC Coil	S.P.D.T.	2500VA at 250VAC 300VA at 30VDC	0 to 240 V AC	10A	7.5A at 240V AC 5A at 30V DC	General AC or DC Control
MF20-A24	Standard Relay 24V AC Coil	S.P.D.T.	2500VA at 250VAC 300VA at 30VDC	0 to 240V AC	10A	7.5A at 240V AC 5A at 30V DC	General AC or DC Control

**Note:** The MF20 flow switch uses reed switches as the primary switching element. Reed switches are one of the most reliable mechanical switching devices ever devised. They offer an operating life in excess of 100 million cycles, however, care needs to be taken to ensure they are not electrically overloaded or if applied in questionable applications, suitable protection should be added to the control circuit.

MADE IN AUSTRALIA BY

**KELCO Engineering Pty Ltd**

ABN 20 002 834 844

Head office and factory

9/9 Powells Road Brookvale 2100 NSW Australia

Phone: +61 2 9905 6425 Fax: +61 2 9905 6420

Email: sales@kelco.com.au Web: www.kelco.com.au

©2008 Kelco Engineering Pty Ltd

**PLEASE NOTE:** Kelco Engineering Pty Ltd reserves the right to change the specification of this product without notice. Kelco Engineering Pty Ltd accepts no liability for personal injury or economic loss as a consequence of the use of this product. All rights reserved copyright Kelco Engineering Pty Ltd © 2008.