

## CR20 MICROFLOW SWITCH

### LOW FLOW CHEMICAL RESISTANT FLOW SWITCH

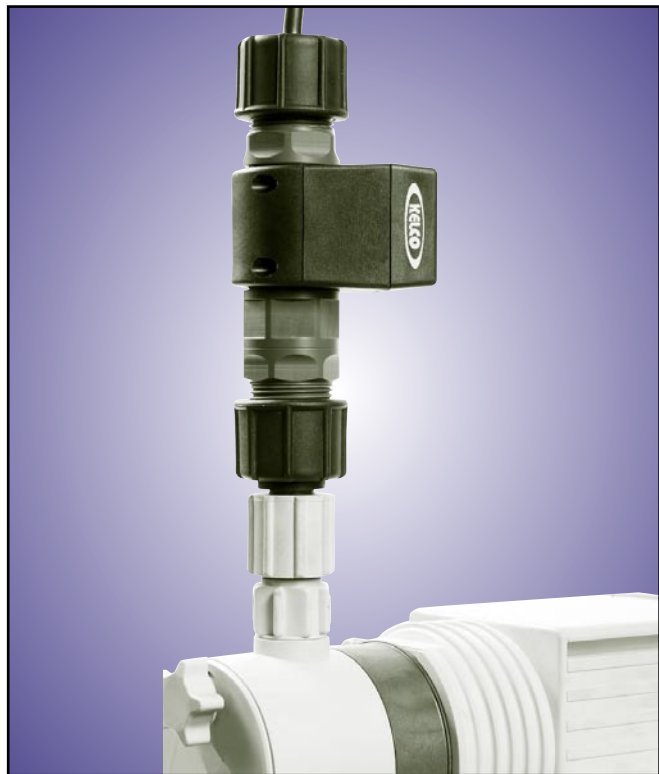

### FEATURES

- DETECTS FLOWS OF LESS THAN 5mL PER MINUTE
- HANDLES CONTINUOUS FLOWS TO 4L PER MINUTE
- SUITABLE FOR PULSED OR CONTINUOUS FLOWS
- SUITS TUBE & PIPES 6mm TO 20mm
- ALL WETTED PARTS UPVC & VITON®
- PVDF MODEL ALSO AVAILABLE
- COMPACT ALL POSITION MOUNTING
- 18 Bar (260PSI) PRESSURE RATING
- FAST RESPONSE TO FLOW LOSS
- EASY TO INSTALL & SERVICE
- SIMPLE AND RELIABLE
- WEATHERPROOF

*The CR20 Microflow switch is a compact in line flow sensor designed to detect extremely low flows. Its main application is in detecting loss of flow in chemical metering and injection systems. The CR20 is made from PVC, or PVDF with VITON, seals, making it ideal for use in such applications.*

### DESCRIPTION

The CR20 Microflow switch operates on the displaced piston principle. Process liquid passing through the switch moves a precision piston. Every time the piston is moved a magnet sealed inside it actuates an external reed switch. The reed switch provides a signal indicating flow. The CR20 can be setup as a normally on or a normally off switch that responds either to flow, or to loss of flow.

### APPLICATIONS

Flow, or loss of flow detection is a critical part of many scientific and industrial applications. Due to their robust construction and high sensitivity the CR20 Microflow switches are suitable for detection of loss of flow in a variety of liquid and gas applications.

The wetted parts of the CR20 are made from UPVC with Viton, O-ring seals. Optional PVDF versions are also available. There are no metal parts within the wet area of the switch. The CR20 can be used with a variety of chemical solutions, including most mineral salt solutions, acids and alkalis. The switch can only be used with clean liquids or gases that are free from suspended solids larger than 20 microns, and free from particulates or sludge residue that is attracted to magnets. Materials such as Ferric solutions, organic solvents, esters and keytones in general should not be used with the CR20.

### ADDITIONAL CONSIDERATIONS

The sensitivity to flow of the CR20 flow switch is not adjustable. It is partially fixed and partially a function of a number of variables. The actual flow rate that the CR20 can detect is affected by the fixed geometry of the switch and by the viscosity of the process liquid. In general, liquids of an SG > 1.0 or kinematic viscosity of >1.0 will proportionally increase the sensitivity of the switch, and slow down its response time. Low viscosity liquids will have the reverse effect. The CR20 is not suitable for use with highly viscous liquids.

### HAZARDOUS APPLICATIONS

The CR20-B Microflow switch can be used in hazardous areas. The flow switch is classed as a simple device and does not contain components capable of storing or producing an electric charge. As a simple device the CR20-B flow sensor can be used in hazardous applications provided it is isolated by an intrinsically safe barrier, a zener barrier.

### NORMALLY ON OR NORMALLY OFF OPERATION

The CR20 Microflow switch can be configured to give a normally on or normally off signal. As supplied the switch is normally off, switching on in response to flow. To reverse this function, simply reverse the inlet and outlet fittings. Unscrew the inlet and outlet adaptors from the switch body and reassemble with the inlet adaptor fitted to the outlet end of the switch and the outlet adaptor fitted to the inlet end of the switch. Note that the electrical module on the switch can be removed and reversed so the electrical cable enters the switch from either the right or left side. Reversing the electrical module does not reverse its electrical function.



**AUSTRALIAN MADE**

# TECHNICAL DATA

## HEAD LOSS

The graph below shows the head loss, or pressure drop, measured between the inlet and outlet of a CR20 Microflow switch and expressed as a function of a continuous flow through the switch. The graph shown is for water at ambient temperature. As an example, from the graph, at 3L/min flow the pressure drop across the CR20 will be 80kPa.

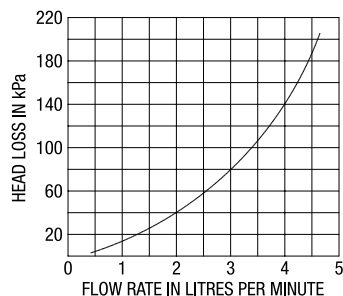

## SWITCH OUTPUT

On a rising flow, the CR20 will switch on or off at 250mL +/- 10% per hour. When applied to a pulsing flow such as from a dosing pump, the nature of the flow needs to be considered. Liquid passing through the flow switch causes its reed switch to change state, either turning it on or turning it off depending on how the switch has been set up. If the liquid stops flowing, the switch will change state, after a delay. The delayed response time depends on the process liquids viscosity. Water for example will give a delay of approximately 7 seconds.

When connected directly to a dosing pump, the flow switch will normally receive a train of pulses of liquid. If the frequency of the pulses is greater than one every 7 seconds, the flow switch will provide a steady output state, while ever the pulses are maintained by the pump. If however the pulse frequency from the pump is less than one pulse every 7 seconds, the flow switch will respond with a series of on and off signals that are directly proportional to the dosing pumps pulse frequency.

## ELECTRICAL

Sensor Model	Module Type	Contact Configuration Maximum	Switched Power Maximum	Switched Voltage Resistive AC (rms)	Switched Current	Inductive Loads	Typical Application
B	Dry Contact Reed Switch	S.P.S.T NO or NC	40Watts	240V AC 200V DC	1 Amp Maximum	Not Suitable	PLC Telemetry and Relay Logic circuits
R	Solid State Relay	S.P.S.T. NO or NC	750W	240V AC	4 Amps	4A at 240V AC	AC control circuits & AC motor control

**Note:** The CR20 Microflow switch uses a dry contact reed switch as the primary switching element. Reed switches are one of the most reliable mechanical devices ever devised. They offer an operating life in excess of 100 million cycles; however care needs to be taken to ensure they are not electrically overloaded. If applied in questionable applications suitable protection should be added to the control circuit. Details of reed switch protection circuits can be downloaded from [www.kelco.com.au](http://www.kelco.com.au)

**Note:** The CR20-R Microflow switch contains a Triac. It can only be used in AC applications. To operate correctly a minimum load of 10mA must be imposed on the switch, at any voltage from 5 to 240 V AC.

## OPTIONS

Various options are available to suit specific OEM applications; these include custom-made process connections, special threads, tube adaptors and pipe spigots in a variety of sizes.

The CR20 Microflow switch can be supplied in PVDF with Viton or EPDM seals, against special order.

## SPARE PARTS

The body assembly and sensor head for the CR20 flow switch are available as spare parts.

## OPERATING PARAMETERS

Switching point on a rising flow (water at ambient temperature)	250mL per Hour +/- 10%
Response to loss of flow (water at ambient temperature)	7 seconds +/- 10%
Maximum recommended operating pressure, (static or dynamic) at ambient temperature	1800 kPa (260 PSI)
Minimum burst pressure at ambient temperature	9700kPa (1400 PSI)
Maximum process liquid temperature	60°C
Minimum liquid temperature	0°C
Maximum recommended continuous flow through switch	4 Litres per minute
Liquid Ph range	1 to 14
Maximum process liquid S.G.	1.5
Minimum process liquid S.G.	0.8
Weatherproof rating of electrical module	IP56

## ORDERING

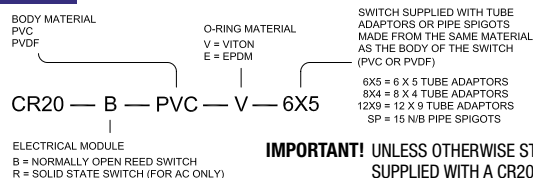

## DIMENSIONS

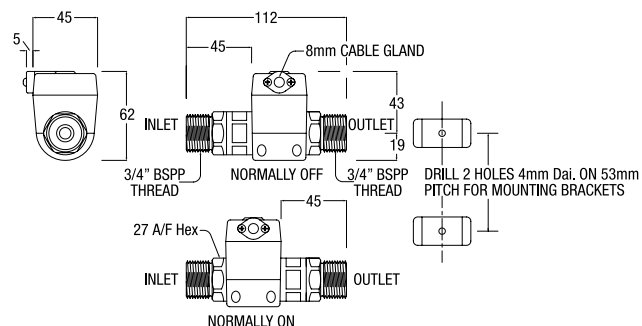

MADE IN AUSTRALIA BY

**KELCO Engineering Pty Ltd**

ABN 20 002 834 844

Head office and factory

9/9 Powells Road Brookvale 2100 NSW Australia

Phone: +61 2 9905 6425 Fax: +61 2 9905 6420

Email: [sales@kelco.com.au](mailto:sales@kelco.com.au) Web: [www.kelco.com.au](http://www.kelco.com.au)

©2009 Kelco Engineering Pty Ltd

**PLEASE NOTE:** Kelco Engineering Pty Ltd reserves the right to change the specification of this product without notice. Kelco Engineering Pty Ltd accepts no liability for personal injury or economic loss as a consequence of the use of this product. All rights reserved copyright Kelco Engineering Pty Ltd © 2009.