

P25 SERIES CORROSION RESISTANT INLINE FLOW SWITCH

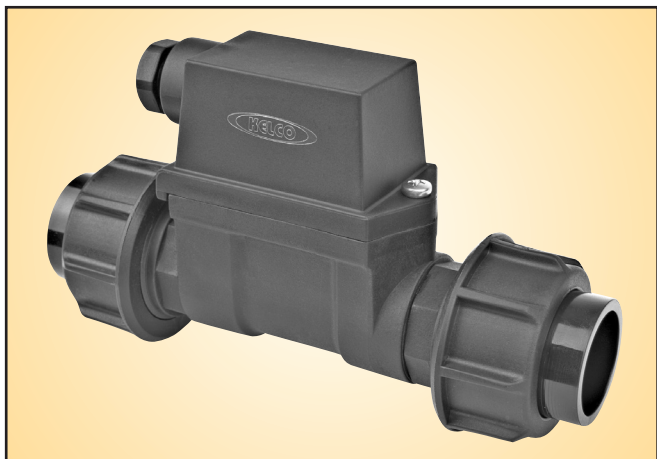

FEATURES

- DIRECTLY CONTROL PUMP MOTORS
- IDEAL FOR PLC AND RELAY LOGIC
- MANUAL OVERRIDE (P25-S MODEL)
- SUITS PIPES 15mm TO 25mm (1/2" to 1") DIA.
- NO METAL PARTS IN CONTACT WITH LIQUIDS
- 100 LITRES PER MINUTE FLOW RATING
- VERSATILE ALL POSITION MOUNTING
- 18 BAR (260 PSI) PRESSURE RATING
- 1P67 WEATHERPROOF HOUSING
- DETECTS VERY LOW FLOWS

APPLICATIONS

- SAFETY SHOWER ALARMS
- LOSS OF PRIME PROTECTION FOR PUMPS
- FLOW MONITOR FOR LARGE DOSING SYSTEMS
- CONSTANT PRESSURE PUMP CONTROL
- CONTROL OF TANK FILLING SYSTEMS
- LOW YIELD BORE PUMP PROTECTION

DESCRIPTION

The P25 inline flow switch is a rugged versatile all position mounting flow actuated switch that can detect the flow of liquids in 15mm (1/2") to 25mm (1") diameter pipes. The P25 can be used in larger pipe systems provided the maximum flow does not exceed 100 litres per minute. The switch can detect very low flows and yet has a low head loss high flow through rating. It can be used to detect continuous or pulsed flows. The P25 finds a myriad of applications in industrial, rural and domestic pumping systems. It is particularly well suited to pressure boosting applications and in the control of constant pressure pumps due to its ability to detect and switch at extremely low flows. In addition the P25 can be used to protect low yield bore pumps and in tank filling applications. There are no metal parts in contact with liquids within the switch, so it is ideal for use in aggressive liquids such as groundwater, seawater and in acidic and alkali solutions.

The P25 flow switch is supplied complete with unions and standard PVC pipe sockets for direct solvent gluing into PVC pipework. The union threads on the P25 are standard parallel BSP form and where required can be used to secure the switch directly into threaded pipework.

AVAILABLE MODELS

The P25 flow switch is available in one of three electrical configurations to suit one of three different pipe sizes. In addition the user has a choice of one of three different flow sensitivity rates, or switching points.

P25-S

The P25 can be supplied with a heavy-duty single pole double throw (S.P.D.T.) mechanical switch specifically designed for the direct control of pump motors up to 1.5kW 2HP. This switch is designated P25-S. This model is also ideal for general control circuit applications up to 500VAC. The P25-S flow switch is only available fitted with a "B" piston. See the table below for the "B" pistons switching point details.

P25-B

The P25-B model contains a dry contact normally open reed switch (S.P.S.T.NO) that closes on flow. This switch is ideal for PLC input, general relay logic and control circuit applications and for telemetry control. The reed switch is rated to 240VAC 40 watts.

P25-C

The P25-C model is similar to the P25-B, except it uses a single pole double throw reed switch (S.P.D.T), as the primary switching element. This switch is suitable for use in low voltage light duty failsafe control circuits and for PLC input and telemetry circuits.

The P25 can be supplied with pipe unions and PVC pipe sockets to suit solvent welding into PVC pressure pipe, in 15mm (1/2"), 20mm (3/4"), or 25mm (1"). In addition, in each case, the male threads on the unions supplied with the flow switch have parallel BSP threads that are 2 pipe sizes larger than the PVC sockets supplied with the switch. For example the 25mm model has unions with 40mm (1 1/2" BSP) male threads. These union threads can be used to mount the flow switch directly into pump discharge ports or into threaded pipework if required. On all models the complete discharge union assembly can be unscrewed and removed from the switch body and the 25mm (1") BSP female thread in the switch body can be used directly as the outlet process connection.

The P25 flow switch is available with one of three different pistons, designated A, B and C. Each piston requires a specific flow rate to cause it to move and actuate the switch.

The switching point for each piston is given in the table below. The table refers to water at ambient temperature as the process medium. Liquids of high viscosity will proportionally lower the switching threshold and equally, low viscosity liquids will proportionally increase the flow rate required to actuate the switch.

SWITCHING POINTS

Available Pistons	Switching point on a slowly rising flow in litres per minute +/- 5%	Switching point on a slowly reducing flow in litres per minute +/-5%	Electrical response time in seconds (approx.)
A	1.0	0.6	0.1
B	4.7	2.7	0.1
C	7.3	4.5	0.1



AUSTRALIAN MADE

TECHNICAL DATA

MANUAL OVERRIDE

The P25-S model is fitted with a manual override. The override is located under a locking cover on the side of the switch body. The override is normally left in the "Auto" position. It can be rotated to "ON" to override the flow switch, regardless of flow. The override can be set to "ON" to allow pumps to prime, in spite of an initial lack of flow. It can also be used to test control circuit wiring during commissioning of pump systems. The P25-B and P25-C models are not fitted with a manual override.

HEAD LOSS

The graph below shows the head loss, or pressure drop, measured between the inlet and outlet of a P25 flow switch and expressed as a function of a continuous flow through the switch. The graph shown is for water at ambient temperature. As an example, from the graph, at 40L/min flow the pressure drop across the P25 will be 10kPa.

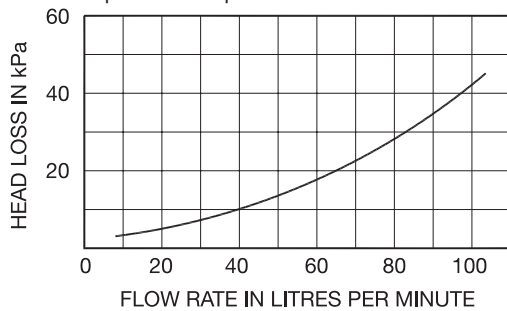

DIMENSIONS

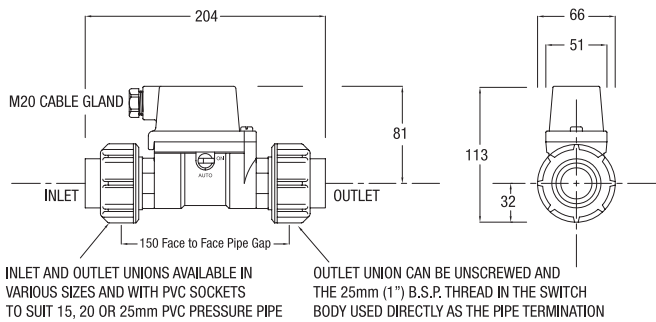

OPERATING ENVIRONMENT

Switching point on a slowly rising flow (water at ambient temperature) +/- 15%	Depends on which piston is fitted to the switch. See the table marked "Switching Points" for details
Minimum gravity head required to actuate the P25-B & P25-C flow switch	1.4 Meters
Maximum recommended continuous flow rate through the switch	100 Litres per minute (Head loss will be < 50kPa at 100 L/min)
Maximum recommended operating pressure, static or dynamic, at ambient temperature	18 Bars (260 PSI)
Minimum Burst pressure at ambient temperature	6000 kPa (865 PSI)
Maximum liquid temperature	60°C
Minimum Liquid temperature	-20°C
Liquid Ph range	1 to 14
Weatherproof rating	IP67

ORDERING

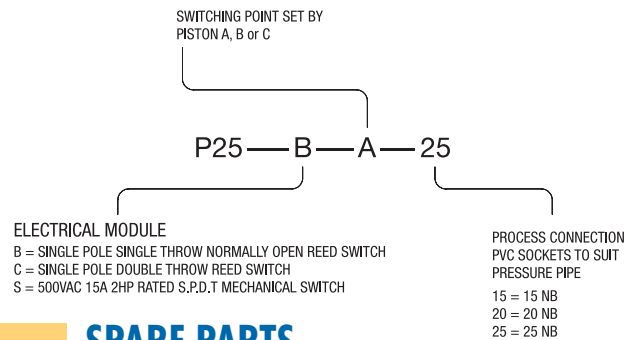

SPARE PARTS

All component parts of the P25 flow switch are available as spare parts.

HAZARDOUS APPLICATIONS

The P25 flow switch can be used in hazardous areas. The flow switch is classed as a simple device and does not contain components capable of storing or producing an electric charge. As a simple device the P25 flow sensor can be used in hazardous applications provided it is isolated by an intrinsically safe barrier, a zener barrier.

ELECTRICAL DATA

Switch Model	Module Type	Contact Configuration	Switched Power Maximum	Switched Voltage Maximum	Switched Current Resistive AC (rms)	Inductive Loads	Typical Application
P25-B	Dry Contact Reed Switch	S.P.S.T NO	40Watts	240V AC 200V DC	1 Amp Maximum	Not Suitable	PLC Telemetry and Relay Logic circuits
P25-C	Dry Contact Reed Switch	S.P.D.T.	20Watts	140V AC 150V DC	1 Amp Maximum	Not Suitable	PLC Telemetry and Relay Logic circuits
P25-S	Heavy Duty Mechanical Switch	S.P.D.T.	1.5kW 2HP	500V AC 250V DC	20 Amps @ 240V AC	Direct Control of Motors to 1.5kW 2HP	AC control circuits & AC motor control

Note: The P25-B and P25-C flow switch use a dry contact reed switch as the primary switching element. Reed switches are one of the most reliable mechanical devices ever devised. They offer an operating life in excess of 100 million cycles; however care needs to be taken to ensure they are not electrically overloaded. If applied in questionable applications suitable protection should be added to the control circuit. Details of reed switch protection circuits can be downloaded from www.kelco.com.au

MADE IN AUSTRALIA BY

KELCO Engineering Pty Ltd

ABN 20 002 834 844

Head office and factory

9/9 Powells Road Brookvale 2100 NSW Australia

Phone: +61 2 9905 6425 Fax: +61 2 9905 6420

Email: sales@kelco.com.au Web: www.kelco.com.au

©2009 Kelco Engineering Pty Ltd

PLEASE NOTE: Kelco Engineering Pty Ltd reserves the right to change the specification of this product without notice. Kelco Engineering Pty Ltd accepts no liability for personal injury or economic loss as a consequence of the use of this product. All rights reserved copyright Kelco Engineering Pty Ltd © 2009