

IPG20 Mk2 INTELLIGENT PUMP GUARD

THE ULTIMATE IN LEAK DETECTION AND LOSS OF FLOW PROTECTION

DESIGNED FOR BOTH FRESH WATER AND
EFFLUENT IRRIGATION SYSTEMS



FEATURES

- Learns the operating pressure
- Fixed or travelling irrigation systems
- Compensates for change in terrain
- Cyclic running for pod systems
- Leak and blockage detection
- Loss of flow protection
- Displays pressure and set points
- 20 Bar / 2000 kPa pressure rating
- Multi voltage operation
- Manual or automatic operation
- IP67 rated

FURTHER INFORMATION

Further information including installation guides, programming guides and videos can be found at the following web page: <http://www.kelco.com.au/ipg20-intellegent-pump-guard>

OUTLINE

The IPG20 Mk2 intelligent pump guard learns the operating pressure each time the system is started and then applies the predetermined under and over pressure set points. This allows for highly targeted leak and over-pressure detection. Designed for either fixed pods or travelling irrigators.

CONSTRUCTION

The IPG20 Mk2 intelligent pump guard is of thermoplastic construction with a 1" BSP process connection. Supplied with 1 paddle to suit pipe sizes 25mm and greater, and 2 trailing wires to suit pipe sizes from 65mm – 100mmID, subject to velocity.

Model Number	Description
IPG20-MK2	For 220 ~ 240VAC or 24VAC or DC operation

TECHNICAL DATA

DIMENSIONS

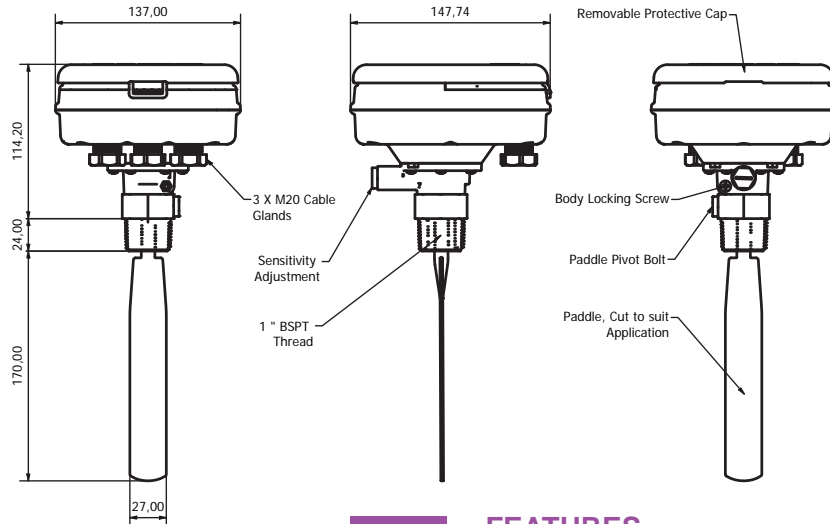

FUNCTIONS

The IPG20 Mk2 intelligent pump guard includes many unique functions as set out below.

Functions (# Settable)
Manual or Automatic operation
Auto terrain compensation (allows for contour change with a travelling irrigator)
Drift allowance in kPa (auto terrain compensation only)
Pre-start delay timer
Use alarm relay
Absolute low pressure (major leak during start up)
Low pressure margin (fine leak detection)
Absolute high pressure (closed valve protection)
High pressure margin (partial blockage detection)
Set point margin (allowable pressure variation during learning process)
Ramp-up timer (allows time to establish stable pressure)
Set point timer
Pressure dip timer
Pressure spike timer
Run on timer (loss of flow)
Cyclic running (not available in auto terrain compensation)
Auto restart on a fault (not available in auto terrain compensation)
Program lock
Displays the system pressure in kPa
Displays the high & low pressure set points
Displays the total time the pump ran in minutes
Displays the reason for stopping on a fault
Instigate learning process using a remote switch (manual operation)
No-flow protection at all times

3 PHASE PUMPING SYSTEMS

The IPG20 Mk2 can be used to control both single and 3-phase pumps provided a 220~240VAC or 24VAC or DC supply is available at the installation site.

FEATURES

Operating Range	
Ambient Temperature Range	1°C to 50°C
Liquid Temperature Range	1°C to 60°C
Ingress Protection Rating	IP67
Pre-Start Delay Timer	Adjustable from 1 second to 27.7 hours in 1 second increments
Start-up Timer (no flow detection)	Adjustable from 1 second to 4 minutes in 1 second increments
Ramping-up Timer (allows pressure to stabilise)	Adjustable from 1 second to 15 minutes in 1 second increments
Run-on Timer (loss of flow detection)	Adjustable from 1 second to 15 minutes in 1 second increments
Pressure Dip Timer	Adjustable from 1 second to 4 minutes in 1 second increments
Set Point Timer	Adjustment in increments of 60 seconds
Cyclic Running & Stopping	Running and stopping times both adjustable from 2 minutes to 99 hours 59 minutes in 1 minute increments
Auto Restart after a fault	Adjustable from 1 minute to 99 hours 59 minutes in 1 minute increments Not available in auto terrain compensation
Maximum Operating Pressure, Static or Dynamic	20 Bars/2000 kPa
Minimum Burst Pressure	> 30 Bar/3000 kPa
Starting Pressure Range	0 to 2000 kPa in steps of 1 kPa
Stopping Pressure Range	0 to 2000 kPa in steps of 1 kPa
Minimum Pressure Differential	1 kPa
Recommended Pipe Size.	25mm (1") or larger. (There is no upper limit)

ELECTRICAL

Supply Voltage	220 to 250 VAC or 18 to 25 VAC or DC (Multi Voltage Input)
Maximum Motor Load	Single phase motors up to 2.4kW maximum at 240VAC (P1). Three phase motors of all sizes via a suitable interposing contactor, no maximum motor size applies
Relay 1 Contact Rating	16 Amps at 240 VAC resistive
Relay 2 Contact Rating	16 Amps at 240 VAC resistive

KELCO Engineering Pty Ltd

ABN 20 002 834 844 Head office and factory: 9/9 Powells Road Brookvale NSW 2100 Australia. Postal Address: PO Box 7485 Warringah Mall Post Shop Brookvale NSW 2100 Australia. Phone: +61 2 9905 6425 Fax: +61 2 9905 6420 Email: Sales@kelco.com.au Web: www.Kelco.com.au

PLEASE NOTE: Kelco Engineering Pty Ltd reserves the right to change the specification of this product without notice. Kelco Engineering Pty Ltd accepts no liability for personal injury or economic loss as a consequence of the use of this product. All rights reserved copyright Kelco Engineering Pty Ltd © 2018 The Kelco IPG20 Mk2 Intelligent Pump Guard is protected by a 12 month return to base warranty. Full details of our warranty can be downloaded from: <http://www.kelco.com.au/warranty>