

## LM SERIES HEAVY DUTY LEVEL SWITCHES

### FEATURES

- 500V AC 15 Amp S.P.D.T switch
- Low Voltage Gold Contact Model Available
- 316 Stainless Process Connection
- Super Tough Billet Aluminium Housing
- Manual Override Built in
- 1" BSP & 1" NPT Models Available
- Seal-less magnetic Drive
- Weatherproof IP67 Housing
- Easily Serviceable

### APPLICATIONS

- Tank and liquid level control
- Low level protection for pumps
- Level control in water treatment
- Chemical tank level monitoring

### OUTLINE

The LM Series side entry level switch provides a reliable accurate solution to tank level control. The switch is constructed from a combination of 316 Stainless Steel and CNC machined aluminium with a Polypropylene float and arm. The level switch can be supplied with a S.P.D.T. 5 to 500 Volt single pole double throw microswitch for general control circuit use or with a S.P.D.T low voltage microswitch for low voltage and low wetting current applications. The LM series level switch is built tough to give a long reliable service life in the most arduous applications.

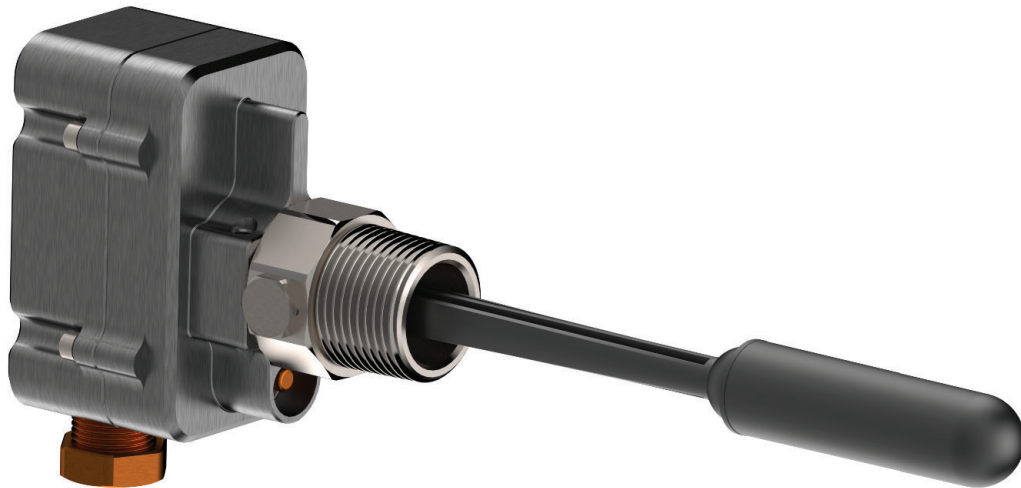

### ORDERING

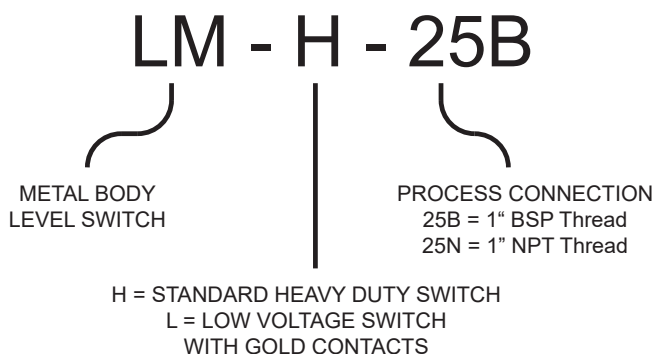

### OPERATING LIMITS

Parameter	Standard LM Series Level Switch
Maximum submergence of the float	100 Metres (328 feet)
Minimum burst pressure of the Polypropylene float at ambient temperature	1800 kPa (260 PSI) (183 Metres or 602 feet of head)
Minimum burst pressure of the switch body at ambient temperature	800 Bars (11600 PSI)
Maximum operating temperature (Process Liquid)	80°C
Minimum operating temperature	-60°C (-76°F)
Minimum liquid S.G.	0.95
Ingress protection rating	IP67

## ELECTRICAL DATA

The LM level switch houses a S.P.D.T (Single Pole Double Throw) switch. The standard H switch is suitable for all general control circuit applications up to 500V AC. It is ideal for the control of pump starters, relay logic circuits, and for the direct control of contactors and timers.

### IMPORTANT

The standard H switch can operate at ANY voltage from 5 to 500VAC. It can be used to directly control pump motors up to 375 Watts (0.5HP) at 240VAC. For larger motors always use an interposing contactor or relay between the level switch and the motor.

## ELECTRICAL LIMITS FOR THE STANDARD H SWITCH

Electrical Data								
RATED VOLTAGE	NON INDUCTIVE LOADS				INDUCTIVE LOADS			
	RESISTIVE LOAD		LAMP LOAD		INDUCTIVE LOAD		MOTOR LOAD	
	NO	NC	NO	NC	NO	NC	NO	NC
125 VAC	15A		3A	1.5A	15A		5A	2.5A
250 VAC	15A		2.5A	1.25A	15A		3A	1.5A
500 VAC	10A		1.5A	0.75A	6A		1.5A	0.75
8 VDC	15A		3A	1.5A	15A		5A	2.5A
14 VDC	15A		3A	1.5A	10A		5A	2.5A
30 VDC	6A		3A	1.5A	5A		5A	2.5A
125 VDC	0.5A		0.5A	0.25A	0.05A		0.05A	0.05A
250 VDC	0.5A		0.5A	0.25A	0.03A		0.03A	0.03A

**Note:** Do not apply maximum voltage at maximum current across the switch contacts. See main data table for current limits at specific voltages and for specific loads.

## ELECTRICAL LIMITS FOR THE L SWITCH

In addition to the standard switch, a S.P.D.T. low voltage switch with gold contacts, designated "L" is also available for low voltage and low wetting current signalling applications.

Maximum Switched Voltage	30VDC
Maximum Switched Current	26mA
Minimum Switched Voltage	5VDC
Minimum Switched Current	1mA

**Note:** Do not apply loads in excess of the limits in the table above. Do not apply inductive or capacitive loads to the L microswitch. The "L" microswitch will be damaged by loads in excess of the limits in the table.

## APPROVED STANDARDS

The standard single pole double throw switch used in the LM-H level switch is approved to the following international standards: UL (File No. E32667), CSA (File No. LR21642) SEV (File No. S20/163) and CE.

## DIMENSIONS

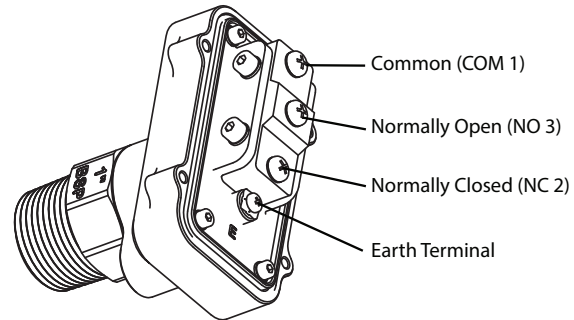
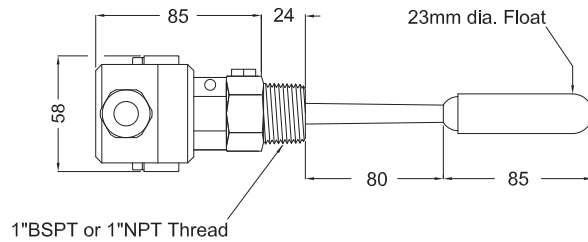
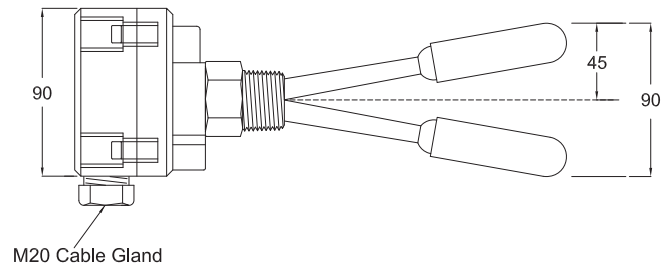

## SWITCHING POINT

The tip of the arm of the LM level switch is free to travel vertically 45mm each side of the horizontal centre line of the switch. The switching point is in the middle of this travel and occurs 2 degrees each side of the horizontal centre line. The movement of the switch arm can therefore be confined to within 3 to 4 degrees each side of horizontal and the switch will operate properly.

## HAZARDOUS APPLICATIONS

The LM-L level switch can be used in hazardous areas. The level switch is classed as a simple device and does not contain components capable of storing or producing an electric charge. As a simple device the LM-L can be used in hazardous applications provided it is isolated by an intrinsically safe barrier, a zener barrier.

## KELCO Engineering Pty Ltd

ABN 20 002 834 844 Head office and factory: 9/9 Powells Road Brookvale NSW 2100 Australia. Postal Address: PO Box 7485 Warringah Mall Post Shop Brookvale NSW 2100 Australia. Phone: +61 2 9905 6425 Fax: +61 2 9905 6420 Email: Sales@kelco.com.au Web: www.Kelco.com.au

**PLEASE NOTE:** Kelco Engineering Pty Ltd reserves the right to change the specification of this product without notice. Kelco Engineering Pty Ltd accepts no liability for personal injury or economic loss as a consequence of the use of this product. All rights reserved copyright Kelco Engineering Pty Ltd © 2018 This Kelco product is protected by a 12 month return to base warranty. Full details of our warranty can be downloaded from: <http://www.kelco.com.au/warranty>