

KELCO IPG20 Mk2 INTELLIGENT PUMP GUARD

INSTALLATION & PROGRAMMING MANUAL

Version 150119

VERY IMPORTANT SAFETY NOTICE
PLEASE READ THIS BEFORE INSTALLING THIS CONTROLLER

The IPG20 Mk2 is an industrial control device. It is specifically designed for use in dairy and agricultural applications. It must never be used for any application other than for the aforesaid purposes. The installation, commissioning of this pump controller requires extensive knowledge of pump engineering and electrical engineering. Installation must always be carried out by a qualified pump engineer and all electrical work associated with this controller must be carried out by a licensed electrician.

IMPORTANT: READ THIS FIRST

DO NOT EXPOSE THE IPG20 Mk2 TO VIBRATION. INSTALL ONLY IN PIPEWORK THAT DOES NOT VIBRATE. *Vibration will damage the electronics within the IPG20 and will void your product warranty.*

OVERVIEW

The IPG20 Mk2 intelligent pump guard is a pressure and flow based device that “learns” the operating pressure each time the system is started. This allows for finely targeted parameters where any significant variation in the operating pressure or loss of flow will trigger an alarm and shut the system down.

Because the operating pressure will change each time the irrigator or pods are moved to a different hydrant or hydrant group, or even a different height on the same hydrant, it is normally impossible to give a high degree of protection against over pressure due to a blockage or low pressure due to a leak. With the IPG20 each time the pumping system is started and after the operator has verified the system is running with no problems the learning phase of the controller can be instigated, either manually, or automatically, after a suitable time. The controller then starts to “learn” the operating pressure. If a stable pressure is reached within the allotted time the switch will lock this pressure in as the set point and apply the predetermined under and over pressure settings. If there is no expected change of pressure; eg. fixed sprinklers, stationary irrigator or irrigator on flat land, then the low pressure and high pressure margin can be set very close to the set point.

With a travelling irrigator Auto Terrain Compensation should be selected. The switch then adjusts itself automatically to compensate for changes in contour. This allows for a very small over and under margin, typically 10kPa or less, which gives a very high degree of protection against leaks or blockages.

THE BUTTONS

The IPG20 is controlled and configured using 4 onboard buttons.

(R) Reset button. Stops the pump and restarts the IPG20 when released.

(^) Up arrow button. For increasing program settings.

(v) Down arrow button. For decreasing program settings.

(P) Programming button. For stepping through the menu and entering settings into memory.

THE LIGHTS

The IPG20 includes 4 multicolour lights to indicate activity.

Flow: This light is **GREEN** when the IPG20 detects flow and **RED** when no flow is detected.

Pump: This light is **GREEN** when a pump is running and **RED** when the pump is stopped.

Timer: This light may be **GREEN** or **RED** when a timer or special function is running.

Remote: This light is **BLUE** when remote input No. 1 is closed and off when the remote is open. The light is **RED** when remote input No. 2 is closed and off when the remote is open. This light is **PURPLE** when both remote inputs 1 & 2 are closed.

LCD SCREEN BACKLIGHT

The LCD backlight can be turned on or off.

To turn the light off press and hold down the **(v)** button. Press and release the **(R)** button. Release the **(v)** button. Repeat to turn the light on. The light remembers the state it was last left in if power is turned off. The light can be left permanently on or off as required.

TEMPERATURE

The IPG20 monitors its internal temperature when running. Pressing the **(v)** button while the controller is powered up displays the current internal temperature of the IPG20.

PRESS (and release) THE (P) BUTTON

When the IPG20 is powered up, pressing the **(P)** button, holding it down

for 1 second and releasing it takes you to the top of the menu. Pressing and releasing the **(P)** button loads whatever the screen is displaying into the iPG20's memory. The memory is non-volatile and settings are retained when power is off. You can exit the menu at any time by pressing and releasing the **(R)** button. Any settings you have made up to that point will be retained. There is no need to step all the way through the menu when making a change to a setting.

INSTALLING THE IPG20

1) Do not install the IPG20 in a fully exposed outdoor location. The IPG20 is weatherproof, however, to ensure a long reliable life from it we recommend it be protected from direct exposure to the sun and rain. A skull cap is provided with the IPG20 and we recommend it be used to protect the IPG20 when direct observation of the LCD screen is not required.

2) Do not expose the IPG20 to freezing. If the pipework in which the IPG20 is installed freezes, the pressure sensor in the controller may fail. If the IPG20 is to be used in areas where low temperatures will be encountered, always lag the pipework for several meters either side of the IPG20. Also lag the base of the IPG20 to prevent the unit and any adjacent pipework from freezing.

3) Do not use the IPG20 in hot water applications. The IPG20 is not designed to be used in water hotter than 60°C.

4) Never expose the IPG20 to static or dynamic pressures greater than 20 Bars, 290 psi.

5) Do not install the IPG20 in a section of pipe that is subject to vibration. Vibration will cause premature failure of the electronic components within the controller.

6) Never install the IPG20 in the suction pipe of the pump or in any location where it may be subject to partial vacuum conditions.

LOCATION

Install this controller in a location that is sheltered from direct exposure to the weather whenever possible. The IPG20 is weatherproof and can be

used in fully exposed locations; however, to ensure a long reliable life from the controller we recommend it be protected from direct exposure to the sun and rain. Intense sunlight will eventually cause discoloration of the clear lid on the controller and will also degrade its LCD screen. It is therefore advisable to always protect the controller from the weather using the clip-on skull cap supplied with the controller.

The IPG20 should be installed in a straight section of pipe preferably with 5 diameters of straight pipe either side of the paddle. The controller can be installed in a suitable pipe socket, tapping saddle or pipe tee. The controller should be installed in the discharge pipework of the pumping system. The IPG20 should not be installed in the suction pipe of a pump as it requires positive pressure to operate properly. The IPG20 can be installed in either a horizontal or vertical pipe. If it is installed in a vertical pipe the flow must be in an upward direction. Do not install this controller on the underside of horizontal pipework.

WARNING: *Never install the IPG20 in the suction pipe of the pump or in any location where it may be subject to partial vacuum conditions.*

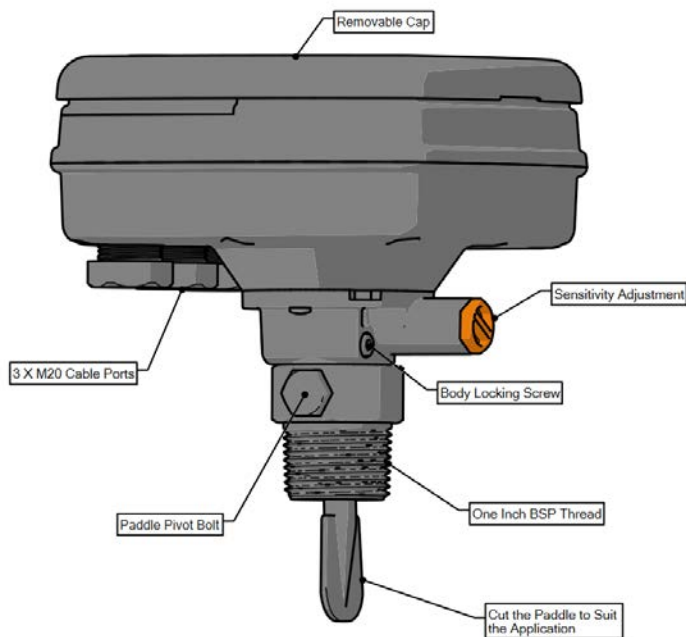

INSTALLATION

The IPG20 pump guard is supplied as two separate assemblies, the paddle assembly and the electrical housing. The paddle assembly should be installed in the pipework first and the electrical housing should then be fitted onto the spigot on top of the paddle assembly, taking care that the sealing O-ring is on the stem and is in location and in good order. There is a flat keying face on the cylindrical body of the paddle assembly that keys the electrical housing onto the paddle assembly and aligns it correctly. It is critical that the keying flat is on the downstream side and at 90 degrees to the axis of the pipework (see sketch). To secure the electrical housing onto the paddle assembly an Allen head cap screw is supplied.

With the electrical housing located on the spigot and in position, press down with the flat of your hand on the top face of the lid of the electrical enclosure. While pressing down, screw the 4mm Allen screw fully through the housing using the 3mm Allen Key (supplied). Tighten the screw and then release your hand from the top of the housing. Pressing down with your hand on the housing preloads the O-ring seal between the housing and the paddle assembly. It enables the M4 Allen screw to easily screw fully through the side of the housing.

Under no circumstances should the electrical housing be twisted or used to screw the paddle assembly into the pipework, or to align the controller with the axis of the pipework. To do so will irreparably damage the controller and void its warranty. Never apply water pressure to the controller unless the M4 locking screw is in place and fully tightened (see sketch for details). To fit the paddle assembly into the pipework use a suitable spanner and the spanner flats provided on the paddle assembly (directly above the process connection thread).

The IPG20 can be installed in either vertical or horizontal pipe. When installed in vertical pipework flow must be in an upward direction past the controller's paddle. The IPG20 is supplied with a 1" BSP process connection. A matching female threaded socket or pipe tee must be provided to fit the controller into pipework.

The IPG20 is supplied with one paddle to suit pipe sizes 25mm and greater, and two trailing wires to suit pipe sizes from 65mm - 100mm ID, subject to velocity.

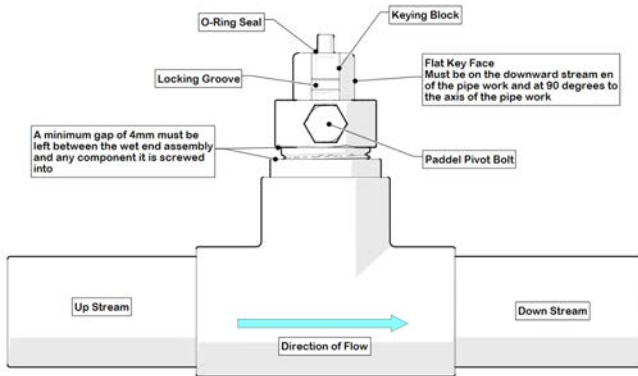
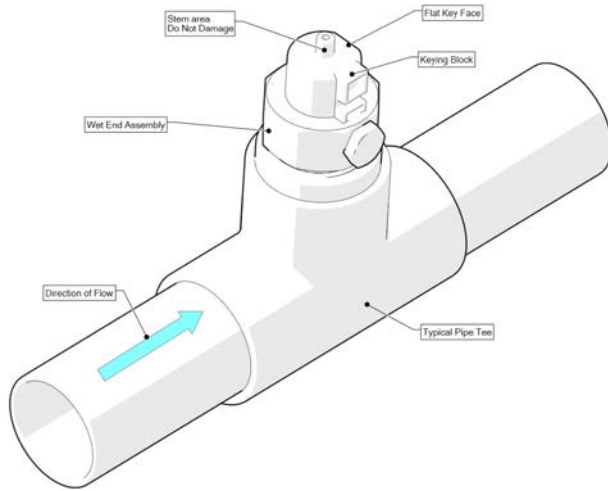

IMPORTANT SAFETY NOTE :-

A pressure relief valve should be fitted to any system that can exceed the pressure rating of any component on that system. Alternately, always confirm that the pressure safety limits of individual items are compatible and not compromised without the fitting of appropriate safety devices, i.e. a Pressure Relief Valve (PRV).

TRIMMING THE PADDLE

The polypropylene paddle of the IPG20 can be cut down to suit the specific pipe size and intended application. Cut the paddle using a hacksaw or tin snips so it clears the sides of the pipe socket and protrudes an appropriate distance, subject to the expected flow, into the pipe when the controller is installed in the pipework. If it is necessary to shorten the trailing wire it must be tig welded to avoid fraying. If you are unsure as to what length the paddle should be, a paddle trimming calculator is available at :

<http://www.kelco.co.nz/paddle-trimming-calculator.php>

If you know what the expected flow rate is the calculator allows you to enter your pipe diameter and paddle dimensions. It will then determine if the selected paddle dimensions are adequate for the application. Spare paddles and trailing wires to suit the IPG20 pump controller are available from Kelco or from your distributor.

Apply sealing compound or Teflon tape to the process connection thread on the controller and screw the controller into the pipework using the spanner flats on the process connection. Do not screw the controller into the pipework by twisting the electrical housing. The controller can be permanently damaged by twisting the electrical housing. When correctly installed there should be a minimum 4mm gap between the top of the pipe socket and the top of the thread on the IPG20. The controller must be square to the axis of the pipework with the direction of flow arrow pointing in the direction of flow.

DETACHING THE ELECTRICAL HOUSING

WARNING: Always switch off the power and de-pressurise the pipe system before attempting to remove the electrical housing.

To allow easy access to the controller's paddle, the electrical housing of the IPG20 can be detached from the paddle assembly. Removing the electrical housing allows access to the paddle without the need to disconnect wiring. To remove the electrical assembly undo and completely remove the M4 Allen head locking screw. Once the locking screw is removed, lift the electrical housing straight off, do not twist it when doing this. Once the electrical housing has been removed, the paddle assembly can be

unscrewed from the pipework using the spanner flats on the body of the paddle housing. Simply reverse this procedure to refit the electrical housing to the controller, taking care to ensure the O-ring on the top of the paddle assembly is in place and is clean and in good condition.

SENSITIVITY ADJUSTMENT

Under the end of the electrical housing on the IPG20 is a red hexagonal dust cap. If you remove this dust cap you gain access to an adjustment screw that allows the paddle preload to be reduced. As supplied the sensitivity adjustment screw is wound fully in. In this position, the paddle is at its least sensitive. In this position, it takes a substantial force from the moving water to move the paddle. If you wind the sensitivity adjustment screw anti-clockwise (outward) the force against the paddle that resists flow will be reduced. The paddle will become increasingly more sensitive and will respond to progressively lower flows the further out you wind the adjusting screw. The total adjustment range is 10 turns of the screw. If you wind the adjustment screw out beyond 10 turns there will not be enough residual force to return the paddle to the off position when flow stops.

The range of sensitivity adjustment will also be affected by the orientation of the controller. In horizontal pipework with the IPG20 mounted vertically the useable range of adjustment is approximately 8 turns. In vertical pipework with the IPG20 installed horizontally the full 10 turn range can be utilised.

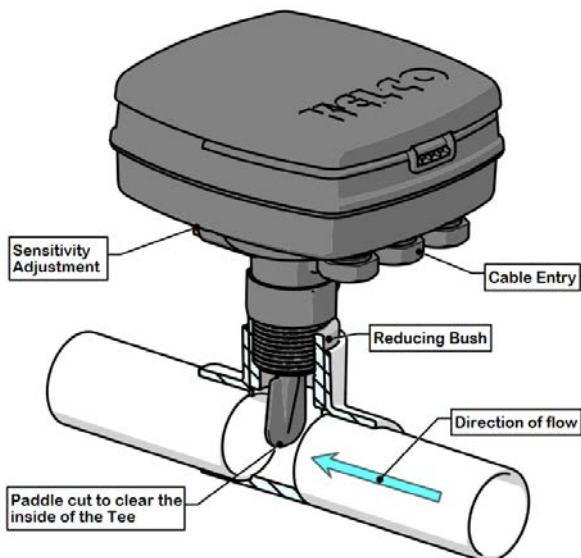

ELECTRICAL INSTALLATION



WARNING

All electrical work associated with the IPG20 must be carried out by qualified electrical personnel and all electrical work must conform to AS/NZ standards and to local wiring rules.

INTRODUCTION

The IPG20 is designed to directly control single-phase pump motors to 2.4kW. via its Relay 1. No interposing contactor is required for such applications. The controller can also be used to control 3 phase pump motors of any size via an appropriate interposing contactor.

WARNING: *The contactor control circuit must never exceed 240VAC. Never connect the IPG20 and contactor coil directly across 2 phases.*

The IPG20 requires a stable 110V to 240V 50/60Hz supply when operated from the mains. It can also be operated from an 18 to 24V AC or DC supply by utilising the low voltage active terminal FELV and neutral terminal N (see the included wiring diagrams). When operated from a low voltage DC supply the terminals FELV and neutral N are not polarity sensitive. Pay attention to cable sizes and ensure cables are adequate for the specific pump motor load. This is particularly important where long cable runs are to be used in the installation. If the voltage drop associated with the starting of the pump motor is excessive the IPG20 may repeatedly reset and not operate properly.



WARNING

The HD terminal must be left unused or only ever linked to Relay 1 Normally Open. It must never be used for any other purpose and it must never be connected to any external device. Under no circumstances connect the HD terminal to the terminals of Relay 2. The HD terminal must be regarded as live at all times and at full mains potential.

THE HD (Heavy Duty) TERMINAL

The IPG20 contains a solid-state switch (HD Heavy Duty drive) that can be used to protect the contacts of Relay 1 by eliminating the destructive arcing caused by the starting and stopping of motors. The solid-state switch is accessible from the HD terminal on the terminal block. We recommend the HD drive be used whenever the controller is used to directly control a single phase motor. The HD drive should not be used when the IPG20 is connected to a contactor, external timer, low wattage relay or to any other external device where voltage free contacts are required. It is strictly intended for the direct control of highly inductive AC motor loads. The HD terminal and the controller's built in relays must never be directly connected to a DC motor under any circumstances. When the HD terminal is linked to the normally open terminal of Relay 1, the HD drive in effect parallels a 42 Amp solid state switch across the relay's normally open contacts. This increases the momentary current carrying capacity of the relay's contacts to well over 60 Amps. The solid-state HD drive is only activated for a brief period when the motor starts and stops. It effectively handles the high inrush current associated with the motor starting, and it provides a current path for the destructive back EMF associated with the motor stopping.

To use the HD drive, place a heavy link wire between the HD terminal and the Normally Open terminal of Relay 1.

BROWNOUT OR BLACKOUT

If a blackout or brownout occurs the IPG20 will not retain any memory of where in its run or stop cycle it may have been, it will simply shut down the pump. When power resumes, the IPG20 will reboot, restart the pump and run any timer settings from the beginning. A manual reboot can be done at any time by pressing and releasing the IPG20's reset button.

CABLES

The IPG20 has 3 X M20 cable glands. As supplied, the cable glands are blanked off. The cable glands can accept cable from 7 to 9mm diameter. See sketch for assembling the cable gland components. The controller is supplied with a set of steel crimp rings. The crimp rings are to provide strain relief for the controller's cables. To use the crimps, place one on the cable approximately 3 to 4mm below the end of the cable's outer sheathing. Crimp the two ears of the ring flat using bull nosed pliers. Pull the cable back through the cable gland until the crimp ring's ears are fully located into the slots in the cable gland housing.

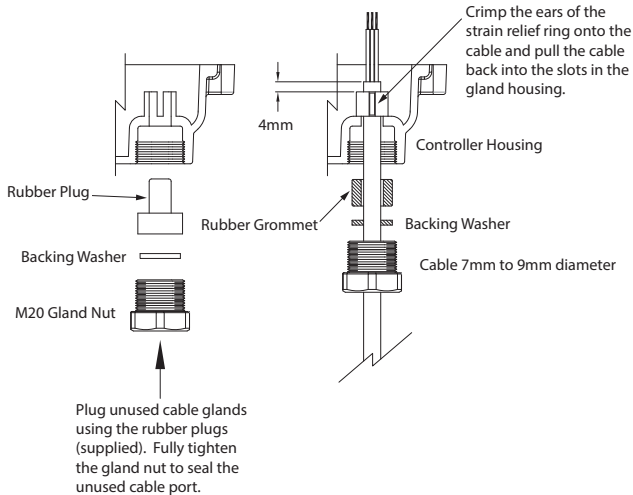

SUPPLY VOLTAGE LIMITATIONS

VOLTAGE LIMITS ON TERMINALS A & N	
Maximum Supply Voltage	260VAC 50/60Hz
Minimum Supply Voltage	110VAC 50/60Hz

VOLTAGE LIMITS ON TERMINALS FELV & N	
Maximum Supply Voltage	25VAC or 25VDC
Minimum Supply Voltage	18VAC or 18VDC

POWERING THE IPG20

POWER REQUIRED TO DRIVE THE IPG20		
With Both Relays Closed	68mA Max at 24VDC	1.63W
With One Relay Closed	52mA Max at 24VDC	1.25W
Quiescent State (relays open)	25mA Max at 24VDC	0.60W

RELAYS

The IPG20 Mk2 houses 2 relays. Relay 1 has S.P.D.T contacts. Relay 2 has S.P.S.T normally open contacts. Relay 1 is normally regarded as the pump control relay and relay 2 is normally regarded as the alarm relay. When operating the IPG20 as a dual pump controller, relay 2 is used to control the second pump.

With the HD terminal linked to the NO terminal of Relay 1, the IPG20 can directly control a single phase motor up to 2.4kW.

*Without the HD terminal link in place, relays 1 & 2 are limited to directly controlling a motor to 0.75kW. **Both relays can control motors of any size via interposing contactors.***

CONTACT RATINGS FOR RELAY 1	
16A at 240VAC	Resistive Load
10A at 240VDC	Motor Load (P1) 2.4kW
50mA at 5VDC	Minimum Load

IMPORTANT: When directly controlling a pump motor through relay 1, always link the HD terminal to relay 1 Normally Open terminal and make sure the maximum switched motor current never exceeds 10 Amps. On a pump motor P1 must not exceed 2.4kW.

REMOTE INPUTS

WARNING: *The low voltage source available at the LV (FELV) terminal is non-isolated and must be regarded as operating at full mains potential whenever the IPG20 is powered from the mains. FELV means Functional Extra Low Voltage and refers to a non-isolated extra low voltage source. With respect to earth, the LV (FELV) terminal is at full mains potential.*

RMT1 MANUAL START

A remote momentary on switch with voltage free contacts can be connected to remote input 1 to start the learning process if fully automatic operation is turned off.

RMT2 REMOTE RESET

A remote momentary on switch with voltage free contacts can be connected to remote input 2 and used to reboot the IPG20. In effect the remote switch acts like the reset button on the IPG20 itself. It causes whatever process is running to stop and for the controller to reboot. If the remote reset switch remains closed the IPG20 displays the message **RELEASE THE RESET BUTTON**. The IPG20 will not reboot until the remote reset button is released.

The supply to the remote switches must be taken from the FELV terminal of the IPG20 when the controller is powered from the mains or from a 24VAC source. The IPG20 must always be powered from the same source as the supply to the remote switch. In all cases the remote switch return wire must be connected to the Remote input RMT1 or RMT2 terminal on the IPG20. The supply to the external switch will range from 12 - 24VDC or from 20 - 35VAC depending on the supply voltage.

WARNING: *Never connect an external power source of any kind to the IPG20's remote input terminal.*

The remote switch can be installed some distance from the IPG20. The maximum distance is limited by cable resistance and capacitance. The total cable resistance must not exceed 5K Ohms with the remote switch closed. The total capacitance of the cable must not exceed 25nF with the remote switch open. Wires to the remote switch should be run separately from power carrying cables. Do not run the remote switch wires in a conduit

that also contains power cables. Capacitive coupling between the adjacent cables may cause false triggering of the IPG20's remote input. For cable runs longer than 150 metres we suggest using 2 separate wires to reduce capacitive coupling between the adjacent wires. When set up this way cable resistance becomes the limiting factor for distance. The following table sets out the resistance of typical copper wire of various diameters.

Note: that the cable resistance refers to the total resistance out to the remote switch and back, as measured at the controller across the 2 remote connection wires with the external remote switch closed. Where the system is switching zones the IPG20 can be triggered to repeat the learning process to learn the pressure of the new zone.

If you select "use alarm relay" and then select "relay closed whenever pump is stopped" (No. 2 Relay) that tells the controller you are going to use valve sequencing. When you then get deeper into the menu and are asked if you want to use cyclic running, if you enter "Yes" it asks you for the running time, followed by the stopping time. After the stopping time a new question pops up "learn the new pressure". (It does not appear unless you have previously selected to use the "alarm relay" and "closed when pump is stopped"). That means it does not confuse users who don't want valve sequencing. By having such a question there it means a user can opt for "No" and still use cyclic running along with an alarm relay that closes whenever the pump is stopped. (In other words, NOT relearn the pressure).

As an example, a water tank is located 2000 metres from the IPG20. Two separate wires each 0.2mm² are run to the remote tank (total wire length is 4000 meters). The resistance as measured across the 2 wires back at the IPG20 (with the tank level switch closed) is 382 Ohms. This is well under the 5,000 Ohm limit. The remote input to the IPG20 will operate properly provide the wires are separated by sufficient distance that the capacitance between them is less than 25nF. Capacitance should be measured between the wires when the remote switch is open and it must be less than 25nF.

Cable Size Square mm	Resistance in Ohms per 1000 Metres
0.2	95.30
0.5	36.20
0.75	24.13
1.0	18.10
1.5	12.10

WIRING DIAGRAMS

PLUG & PLAY CONNECTIONS

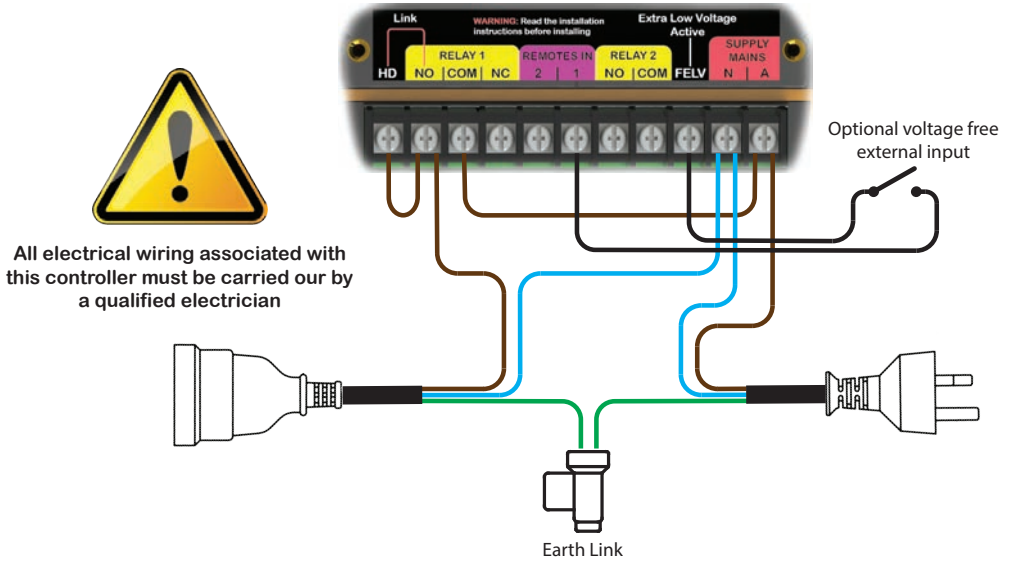

CONNECTIONS FOR A SINGLE PHASE PUMP

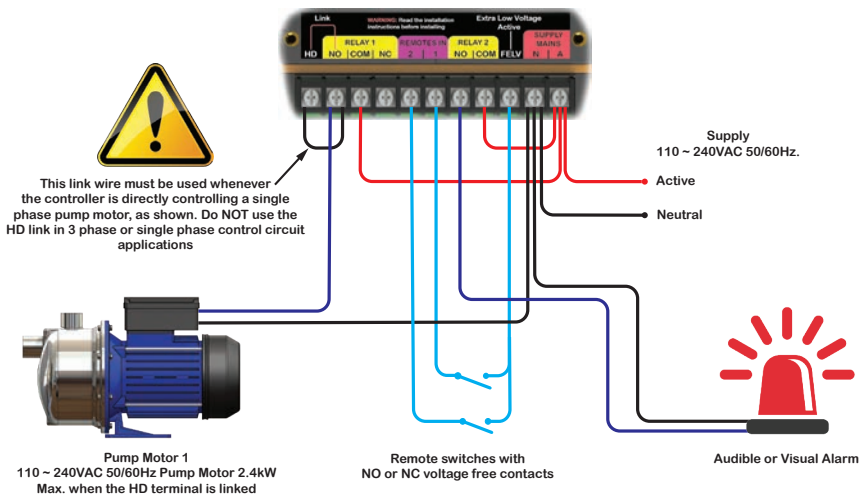

DUAL SINGLE PHASE PUMPS & 2 REMOTE INPUTS

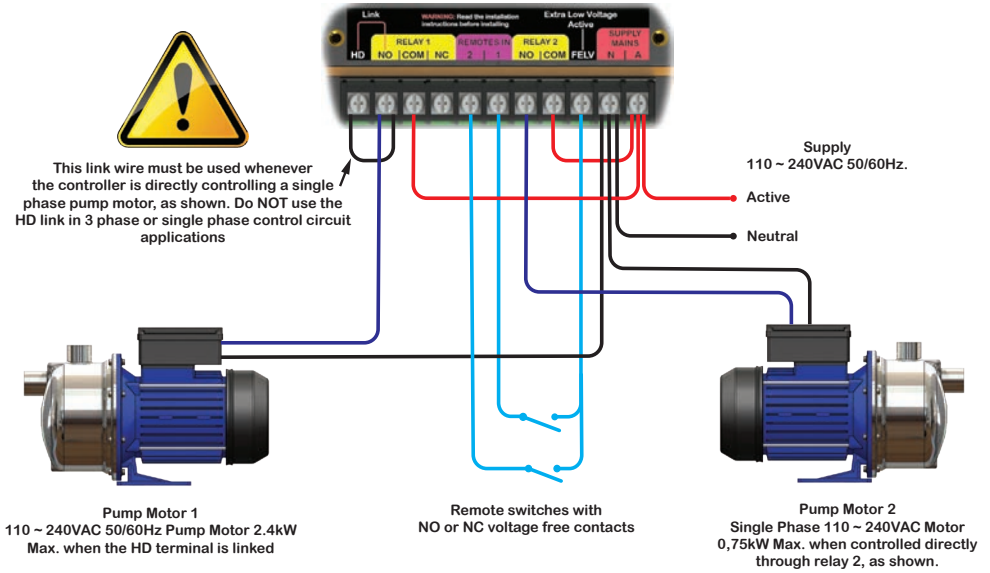

LOW VOLTAGE SUPPLY

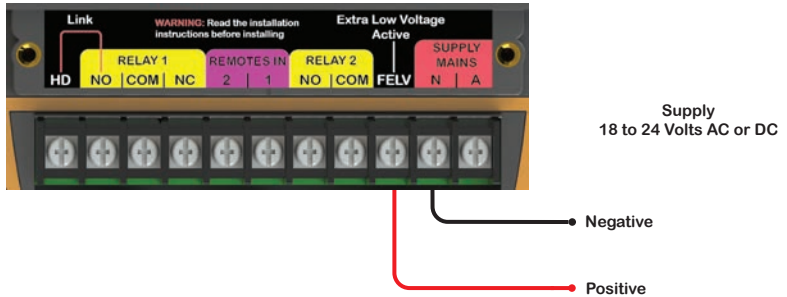

BASIC 3 PHASE PUMP CONTROL

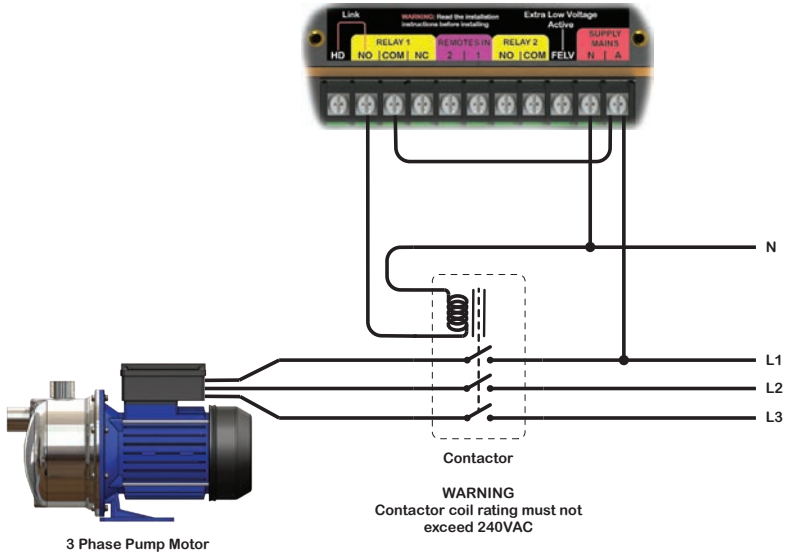

DUAL 3 PHASE PUMP CONTROL

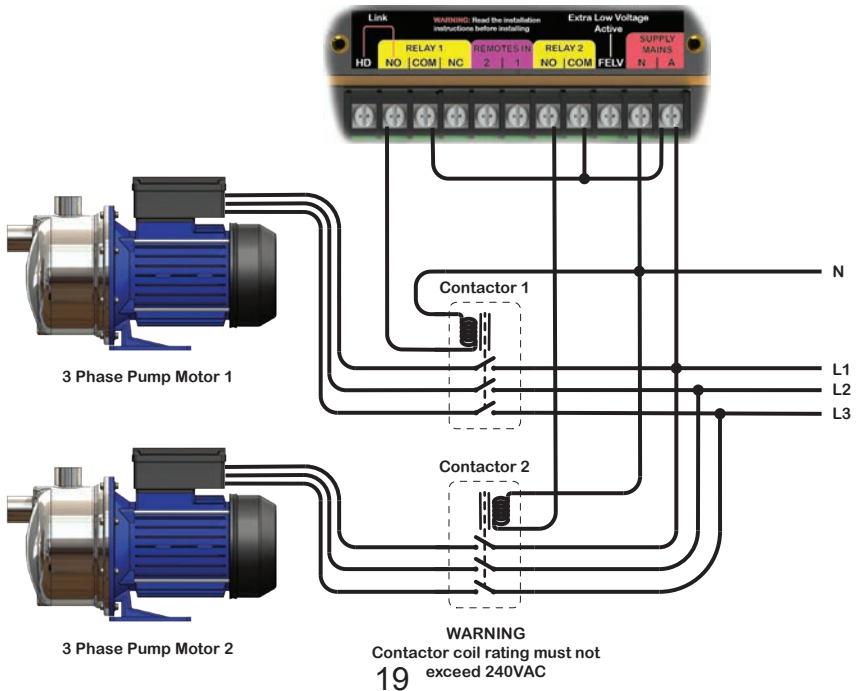

3 PHASE PUMP WITH ALARM AND REMOTE SWITCH

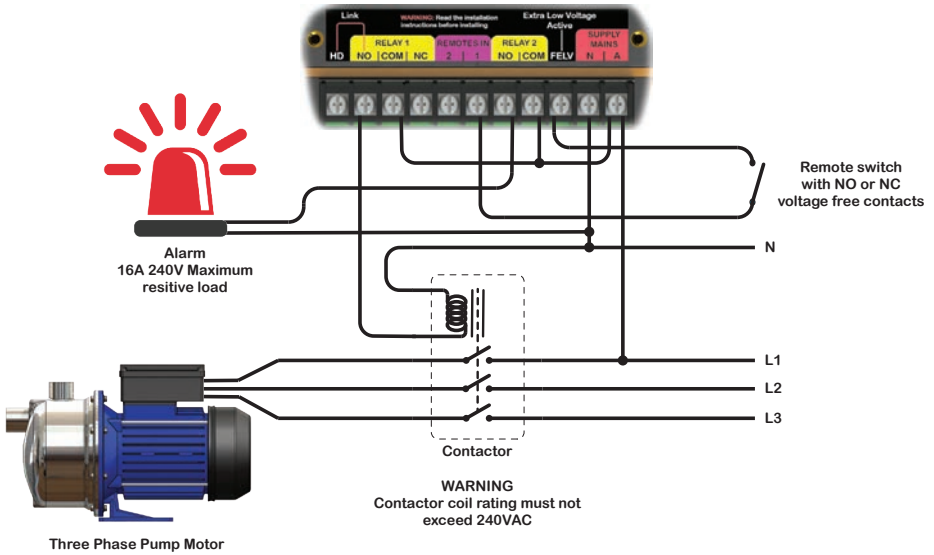

3 PHASE PUMP WITH 24V CONTROL CIRCUIT & SOLENOID VALVE

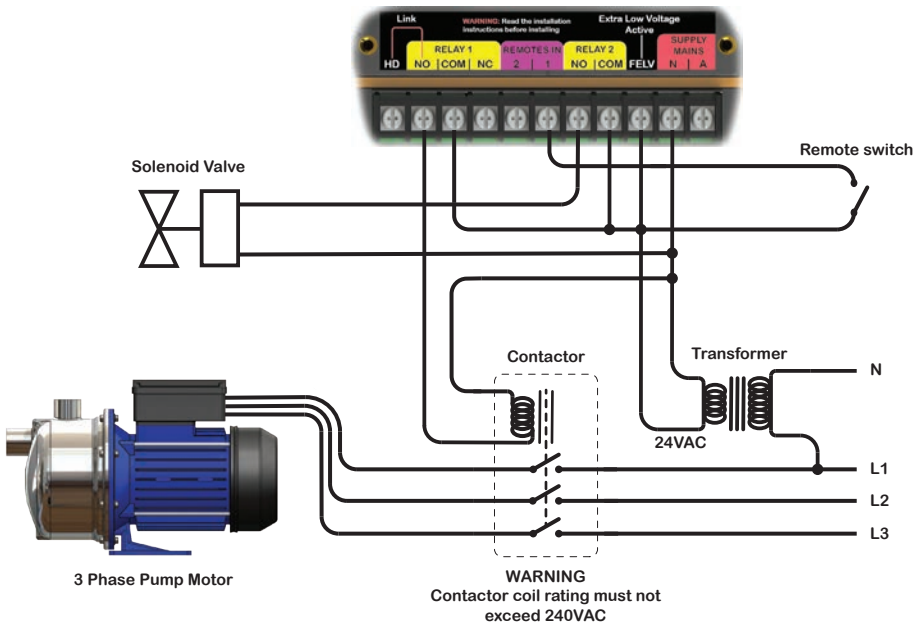

3 PHASE PUMP WITH 240V CONTROL CIRCUIT & REMOTE 24V SOLENOID VALVE

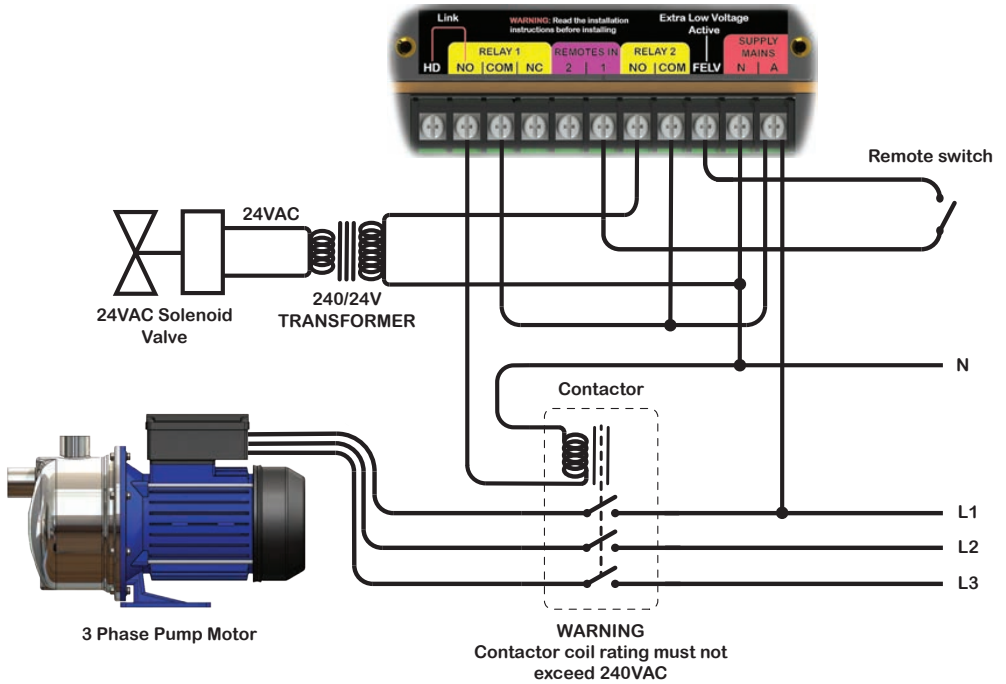

12VDC IPG20 Mk2 CONTROLLING A SINGLE PHASE PUMP



This link wire must be used whenever the controller is directly controlling a single phase pump motor, as shown. Do NOT use the HD link in 3 phase or single phase control circuit applications

Supply Active

Supply: 120 ~ 240VAC 50/60Hz

Supply Neutral

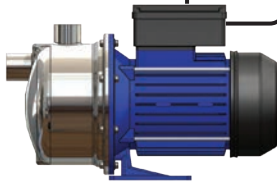

Pump Motor
120 ~ 240VAC 50/60Hz Pump Motor 2.4kW
Max. when the HD terminal is linked

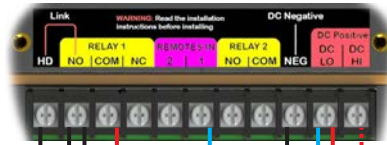

Alternate Positive
14 ~ 40VDC

Positive

Supply 11 - 24VDC

Negative

Remote switch with
NO or NC voltage free contacts

IMPORTANT
Remote input must be sourced
from the supply positive terminal

THE 12VDC IPG20 Mk2

A low voltage DC version of the IPG20 Mk2 is available for battery operation and for use in solar pumping systems. Functionally the 12V DC model is the same as the mains voltage model except for the terminal block markings. On the 12VDC model the active and neutral terminals are replaced by a positive + and a negative – terminal. Supply voltage across the positive and negative terminals must never exceed 24VDC or the flow switch will be damaged. The supply terminals are reverse polarity protected, however, the flow switch will simply not operate unless the supply polarity is correct.

If a remote switch is connected to the 12V DC IPG20 Mk2 the supply to the remote switch must be taken from the positive terminal on the IPG20. The remote switch and its connecting circuit will then operate at 12VDC.

PROGRAMMING THE IPG20

For a description of the functions of the buttons and lights, please read pages 2 and 3 of this manual before proceeding.

RESTORING FACTORY DEFAULTS (Purging the Settings)

You can restore the IPG20 to its default factory settings at any time by pressing and holding down the **(P)** button and pressing and then releasing the **(R)** button. Once the **(R)** button has been released, release the **(P)** button. The screen then displays **SETTINGS CLEARED PRESS P** Doing this removes any settings you may have entered and restores the controller to its default state.

LOCKING & UNLOCKING THE IPG20

The IPG20 is supplied by the factory in an unlocked state and can be programmed using its buttons. To prevent unauthorised personnel from altering its settings, the programming button **(P)** can be locked.

LOCKING THE IPG20

To activate the lock, press and hold down the **(Λ)** and **(V)** buttons and then press and release the **(R)** button. Continue to hold the **(Λ)** and **(V)** buttons down until the screen displays **LOCK**. (takes about 2 seconds) release the **(Λ)** and **(V)** buttons. The IPG20 is now locked. When locked, pressing the **(P)** button will not allow access to the IPG20's menu, instead a message **PROGRAM LOCKED PRESS RESET** is displayed on the screen.

UNLOCKING THE IPG20

To unlock the IPG20 repeat the above procedure, press and hold down the **(Λ)** and **(V)** buttons and then press and release the **(R)** button. Continue to hold the **(Λ)** and **(V)** buttons down until the screen displays **UNLOCKED**. (takes about 2 seconds) release the **(Λ)** and **(V)** buttons.

GETTING STARTED

1) Use the least number of functions possible. Do not program in functions you do not specifically require, as to do so will make the system's operation unnecessarily complicated and may introduce unpredictable interactions between the various functions.

2) When changing modes always start by purging the previous settings, to restore factory defaults, before proceeding. This ensures no conflicts occur between previously set functions and new functions.

3) Set realistic and sensible values into the various functions. For example, do not set a pump to stop at a lower pressure than it is set to start at. Always set the controller's starting and stopping pressure differential to as wide a difference as possible.

The IPG20 intelligent pump guard is a pressure and flow based device that “learns” the operating pressure each time the system is started. This allows for finely targeted parameters where any significant variation in the operating pressure or loss of flow will trigger an alarm and shut the system down.

With irrigation systems such as farm dairy effluent the operating pressure will change each time the irrigation system is moved to a different hydrant or even a different height on the same hydrant. It is normally impossible to give a high degree of protection against over pressure due to a blockage or low pressure due to a leak. With the IPG20 each time the pumping system is started and after the operator has verified the system is running correctly the learning phase of the controller can be instigated.

The controller then starts to “learn” what the operating pressure will be on this particular set up. If a stable pressure is reached within the allotted time the switch will lock this pressure in as the set point and apply the predetermined under and over pressure settings. If there is no expected change of pressure; eg. fixed sprinklers, stationary irrigator, travelling irrigator on flat land and little change in the liquid level relative to the IPG20 then the low pressure and high pressure margin can be set very close to the set point. The pressure change only relates to each pumping cycle. For instance if the pumping cycle is going to be 2 hours we are only concerned about any likely pressure change during that time. If the source is gradually being depleted from day to day the switch will automatically compensate for that each time it starts.

Once the switch has locked in the set point it will monitor the pressure and

flow, and any loss of pressure or flow outside the margins will trigger a shut down after the pre-set delays expire. The switch will then display the reason for the shutdown, and if configured, close the alarm relay to trigger an optional external alarm or dialler which can text to alert the operator of a problem. If the system recovers within the pre-set delay period it will resume normal operation.

This method of fault detection is particularly suited to systems where the pressure will change if there is a leak or blockage.

With a travelling irrigator on undulating terrain Auto Terrain Compensation should be selected. The switch will then adjust itself to compensate for a changing contour. This allows for very small over and under pressure margins which gives a very high degree of protection against leaks or blockages.

DETERMINE THE PRESSURES

When pumping to a hydrant or group of hydrants for the first time, once it has been confirmed there are no leaks or blockages and the switch has locked in a set point the operating pressure should be recorded against the hydrant number or numbers as a group. The recorded pressure can then be used as a useful reference for subsequent pumping to the same hydrant or group of hydrants. If the pressure is the same as it was previously then it can be assumed there are no leaks or blockages.

Alternatively the irrigation system should be checked visually each time the pump is started.

THE IPG20 FUNCTIONS (#Settable)

Manual or automatic operation
Auto terrain compensation (Travelling irrigator)
Drift allowance in kPa (Auto terrain compensation only)
Pre-start delay timer
Alarm relay (Configurable, eg. priming valve, alarm light, etc)
Absolute low limit (System pressure must always be above this)
Low pressure margin (Fine leak detection)
Absolute high pressure limit (Overpressure)
High pressure margin (Partial blockage)
Set point margin
Start-up timer (Loss of flow protection)
Ramping up timer (Manual operation only) (Pipe filling)
Auto start after timer (Automatic operation only) (Pipe filling)
Pressure dip timer
Pressure spike timer
Run-on timer (Loss of flow protection)
Cyclic running (For use with pod systems)
Auto restart on a fault (Not available with auto terrain compensation)
Valve sequencing. Uses the second relay to trigger a valve change and relearns the pressure on the new zone
Displays the system pressure in kPa
Displays the high & low pressure margins
Displays the time the pump ran for
Displays the reason for stopping on a fault
Instigate learning process using remote switch (Manual operation only)
Restart the system using remote switch (Automatic operation only)
No-flow protection at all times
Stops the pump instantly on absolute high pressure
Stops the pump on absolute low pressure
Stops the pump on low pressure margin after delay
Stops the pump on high pressure margin after delay

SUGGESTED FIRST SETTINGS WITH TRAVELLING IRRIGATOR AND AUTOMATIC STARTING

These settings are suggestions to get started. All final settings are site specific and must be relevant to the installation.

Displayed on screen	Suggested setting	Function
Auto terrain compensation	On	Allows pressure change due to contour change.
Drift allowance	10kPa	Allows 1 meter per minute of height change for irrigator
Fully Automatic operation	Yes	Pump will be started after the "start after" time
Prestart delay timer	Optional	Used to delay the pump start
Use alarm relay	Optional	Configurable, eg. turn on a stirrer or a priming valve
Absolute low limit	Set to 50kPa below lowest operating pressure	Protection against a major leak or broken main line
Low pressure margin	20kPa (Small leak)	More than 20kPa pressure drop will trigger the dip timer
Absolute high limit	Set to below max head of pump and below max pipe pressure and at least 50kPa above expected maximum operating pressure	Protection from overpressure
High pressure margin	20kPa (Slight blockage)	More than 20kPa pressure rise will trigger the spike timer
Set point margin	20kPa	Allowable pressure variation the switch can learn within
Start-up timer	10 seconds	Allowable time with no flow
Auto start after	300 seconds	Time to pipe fill and reach a stable pressure
Pressure dip timer	20 seconds	Time allowed before stopping the pump after a leak develops
Pressure spike timer	20 seconds	Time allowed before stopping the pump after a partial blockage
Run on timer	10 seconds	Allowable time after flow is lost
Accept settings	Yes	Select "No" if you want to go through the settings again

SUGGESTED FIRST SETTINGS WITH FIXED SPRINKLERS AND AUTOMATIC STARTING

These settings are suggestions to get started. All final settings are site specific and must be relevant to the installation.

Displayed on screen	Suggested setting	Function
Auto terrain compensation	Off	Not required for fixed pods
Fully Automatic operation	Yes	Pump will be started after the "start after" time
Prestart delay timer	Optional	Used to delay the pump start
Use alarm relay	Optional	Configurable, eg. turn on a stirrer or a priming valve
Absolute low limit	Set to 50kPa below lowest operating pressure	Protection against a major leak or broken main line
Low pressure margin	20kPa (Small leak)	More than 20kPa pressure drop will trigger the dip timer
Absolute high limit	Set to below max head of pump and below max pipe pressure and at least 50kPa above expected maximum operating pressure	Protection from overpressure
High pressure margin	20kPa (Slight blockage)	More than 20kPa pressure rise will trigger the spike timer
Set point margin	20kPa	Allowable pressure variation the switch can learn within
Start-up timer	10 seconds	Allowable time with no flow
Auto start after	300 seconds	Time to pipe fill and reach a stable pressure
Pressure dip timer	20 seconds	Time allowed before stopping the pump after a leak develops
Pressure spike timer	20 seconds	Time allowed before stopping the pump after a partial blockage
Run on timer	10 seconds	Allowable time after flow is lost
Accept settings	Yes	Select "No" if you want to go through the settings again

MANUAL OPERATION

In manual operation the learning phase of the start-up process is instigated by the operator activating the remote switch once it is established the system is running as expected, and at a pressure which is appropriate for the particular outlet/hydrant setup.

The IPG20 provides the user with a non-isolated nominal 24VAC supply from its FELV (Low Voltage) active terminal whenever it is operated from the mains or from a 24VAC supply. The 24VAC supply can be connected through a remote switch and the return wire can be connected to the “R” (remote input) terminal on the IPG20’s terminal block.

When operated from a 24VAC / DC supply, the 24V active or the supply positive can be used as the source of low voltage to the remote switch and the return wire can be connected to the “R” terminal. It is critical that the remote switch has voltage free contacts. Under no circumstances apply an external voltage directly to the “R” terminal of the IPG20 pump guard.

A remote momentary on switch can be used to actuate the IPG20 controller. ***This is necessary if manual operation is selected in the program.***

It is important that there are no leaks or other problems at this stage as they could be locked in by the switch as being normal.

If the remote switch is not activated within the allotted ramp-up time the switch will shut down the pump and display an error message.

AUTOMATIC OPERATION

In automatic operation after a predetermined ramp-up time to allow the system to achieve a stable pressure the switch will go into its “learning” mode without input from the operator, and if the pressure is stable will lock in the set point pressure for that particular outlet/hydrant setup. This mode allows for the controller to be remotely started, perhaps by an auto dialer, level switch or other device.

It is important that there are no leaks or other problems at this stage as they could be locked in by the switch as being normal. If the automatic mode is selected it is strongly recommended that a visual check of the system is done.

AUTO TERRAIN COMPENSATION

Where a significant change in pressure is expected due to either a change in the water level relative to the IPG20; eg. pumping from a small tank with the switch in a fixed position, or a travelling irrigator moving over a changing contour then auto terrain compensation can be used.

In this mode, the switch constantly monitors the pressure relative to the set point pressures and if the pressure changes slowly within the ranges specified then the switch will move the set points to accommodate the gradual change in height of the irrigator or water level. This means the tolerance to a change in pressure can be very fine giving un-paralleled leak detection. *This is described as drift allowance and expressed as kPa per minute.*

For example, if a travelling irrigator is moving either up or down a slope then the expected change in pressure is directly related to the change in height. If the irrigator travels 100 meters per hour and the steepest slope it is expected to move over is 5 meters per 100 meters then the expected change in pressure will be 5 meters (50kPa) per hour. The switch calculates this every minute so the switch setting would be $50\text{kPa}/60\text{ minutes}=0.83\text{kPa}$ expected pressure change per minute. In theory then a 1kPa setting would be sufficient. In practice a 1kPa setting would have very little tolerance for an unexpected larger pressure change such as a sudden dip in the paddock and the small pressure variations from the pump so a more realistic setting is advisable.

If the switch sees a pressure change just outside what it expects as the terrain changes it will shut down the pump and display the pressure set point it was using at the time and the amount of pressure outside the set points that caused it to trip. By doing this the operator can differentiate between a setting which is too fine, to a trip from a genuine leak or blockage. As the set point pressure moves up or down with the terrain it is important to realise the sum of the operating pressure and the high or low margins

cannot be greater or less than the overriding high or low set points. For example if the low pressure margin is 10kPa and the absolute low pressure limit is set to 300kPa if the operating pressure falls below 310kPa the switch will see this as an error and will shut down and display “setting error check settings” message.

PRE-START DELAY TIMER

The pre-start delay timer delays the starting of the pump for a selectable period. It can be set from zero to 99999 seconds (27.7 hours) in one second increments. If you choose to use this timer the actual starting of the pump will be delayed by whatever delay you set this timer to. Each time the controller is switched on it boots up and is prevented from starting the pump for the set time period. As soon as the set time has elapsed the pump will start and run normally, given there is safe flow. The pre-start timer can be used to allow peripheral equipment time to boot up. For example, some VS drives require a few seconds to stabilise and the IPG20’s pre-run timer can hold off the starting of the pump until the whole system has stabilised. The pre-start timer can also be used to stage or stagger the starting of multiple devices. It is often desirable to avoid the high current draw of multiple motors starting together, and the pre-start delay timer can facilitate this function.

USE ALARM RELAY

Having decided whether or not you require an external input and pressed (P), the screen that follows asks you if you want to use the IPG20’s alarm relay. The IPG20 has a second relay (Relay 2) that provides a set of 240VAC 16A rated normally open voltage free contacts. The contacts of the alarm relay can be configured in a variety of ways both for alarm functions and to control all sorts of external equipment. For example, to control a mixer during the pre-start delay as previously described.

If you select YES to the “Use Alarm Relay” question and press (P) there follows a menu that allows you to select the way in which the relay will behave. Pressing the up or down buttons allow you to move from one choice to the next. Pressing (P) confirms your selection and moves you to the next main menu function. If you decide to use the alarm relay, it can be configured in the following ways: -

Closed if any fault develops

If the pump is stopped on any fault condition the alarm relay will close its contacts. This can be used for an alarm light or, perhaps, a dialer to alert the operator of a problem.

Closed only if flow stops

This menu choice only closes the alarm relay if a true loss of flow is detected. In any other fault condition the IPG20 will shut the pump down and display an appropriate message as to what the fault was but the alarm relay will remain open unless the specific condition, in this case loss of flow, is detected.

Closed whenever pump is off

With this choice, the alarm relay will act as a set of contacts that are the reverse of the main pump relay's contacts. When the pump relay (Relay 1) is on the alarm relay's contacts will be open and when the pump relay is off the alarm relay's contacts will be closed. This configuration has all manner of applications in general control and in operating peripheral equipment.

This will also enable valve sequencing further in the program.

Closed whenever pump is on

This configuration means the alarm relay will mimic the main pump relay. It will be on when the pump is on and off when the pump is off. Since Relay 1 and Relay 2 are electrically and mechanically separate this configuration allows two separate circuits to be controlled in synergy.

Closed on a high pressure fault

The alarm relay would only close if the pressure stays above the high pressure margin for the predetermined time.

Closed on a low pressure fault

The alarm relay will only close if the pressure stays below the set point margin for a predetermined time.

Closed on very low pressure fault

The alarm relay will only close if a very low pressure is detected.

Closed on very high pressure fault

The alarm relay will only close if the pressure rises above the very high pressure setting. There is no time delay on this setting.

Closed if ramp up timer times out

The alarm relay will only close if the ramp up timer times out. This can warn the operator he has failed to instigate the learning phase in the allotted time.

Closed if reference pressure is not stable

This will only close the alarm relay if the controller has been unable to lock in a set point because the pressure has not stabilised.

Indicate use of remote input

This will make the alarm relay contacts open and close every second during learning mode. This can be used to operate a light so the operator knows the switch is in its learning mode.

Alarm relay timer

This allows for control of axillary equipment such as stirrers, priming valves and any other device that it is useful to run with, or prior to the pump starting.

Once selected, it closes the alarm relay contacts either as soon as the prestart delay starts, or if the prestart delay is not selected it will close the contacts while the pump is running. If a time is selected it will run for that period then open the alarm relay contacts. If no time is selected it will hold the relay contacts closed during the prestart delay and continues to hold them closed until the pump shuts down in normal operation or due to a fault. e.g. start a stirrer before the pump but continue to run the stirrer while the pump is running.

ABSOLUTE LOW LIMIT

This is an over-riding low pressure setting that gives overall protection against a major breach in the system that may have occurred between irrigation cycles. This would be set just below what would be the lowest operating pressure expected anywhere in the system. If the pressure drops below, or never achieves, this setting the IPG20 will shut down the

system and display “pressure too low”.

LOW PRESSURE MARGIN

This is the pressure allowed below the operating set point. If the operating pressure is not expected to change on any given “run” then this margin can be set very close to the set point but allow for small pressure fluctuations which can be present. This setting will detect a leak in the system that drops the pressure below the low pressure margin

ABSOLUTE HIGH LIMIT

This would normally be set at the highest expected pressure anywhere in the system or perhaps at the maximum pressure rating of the pipeline.

The absolute high limit is the maximum pressure you want the system to reach before shutting down. The range of adjustment is 0 to 2000kPa. The high pressure trip point must be set to some value higher than the low pressure trip point. If you try to set the high-pressure trip to a lower value than the low pressure trip point the IPG20 will not accept the setting and advise you to check your settings. If you choose to leave the high pressure trip point set at zero, meaning you don't want an upper pressure limit, then the IPG20 will automatically set it for you to 2000kPa which is the maximum pressure the IPG20 itself can continuously tolerate. When the absolute high limit is reached any other settings will be over-riden and the system will be shut down immediately.

HIGH PRESSURE MARGIN

This is the pressure allowed above the set point.. If the operating pressure is not expected to change on any given “run” then this margin can be set very close to the set point but allow for small pressure fluctuations which can be present. This setting can be used to detect a partial blockage.

SET POINT MARGIN

The set point will only be locked in if the switch measures six readings within the margin. This margin allows for some pressure variation as the pressure stabilises, eg. some air still being purged from the system. A setting of 20kPa is generally OK.

START-UP TIMER

The IPG20 uses a paddle to detect flow. The paddle is held in the no-flow position by an adjustable magnetic screw that is located in a port under the electrical housing of the pump guard. If flow pushes against the paddle, the paddle moves. The movement is detected by the pump guard and identified as flow. Initially in a system that is not running or has all its valves shut there will be no flow and the paddle will be in the off, or no flow, position. In order to override this initial off state and allow the pump to start the pump guard uses the start-up timer.

The timer ignores the initial off state of the paddle and allows the pump to run for a settable time. As soon as flow is detected the start-up timer terminates its run and hands control of the pump over to the paddle. The start-up timer is adjustable from 0 – 240 seconds (0 – 4 minutes) in 1-second increments. The value you enter will depend entirely on your pumping system. For a fully primed system the start-up timer may only require one or two seconds to establish flow. In a submersible bore pump installation with a self-draining riser it may take several minutes to establish flow past the paddle.

RAMPING UP TIMER - Manual operation only

This timer must be set for sufficient time to allow the system pressure to stabilise before the switch goes into learning mode. Allowance should be made to fill any lines which may drain when not in use and to purge any air from the system.

AUTO START AFTER TIMER – Automatic operation only

This timer must be set for sufficient time to allow the system pressure to stabilize before the switch goes into learning mode. Allowance should be made to fill any lines which may drain when not in use and to purge any air from the system.

SET POINT TIMER

The set point timer is imbedded in the program and not available in the menu. There is a maximum of 300 seconds (5 minutes) available to obtain 6 readings which are taken 10 seconds apart.

The set point timer is the time allowed for the set point to be measured and locked in once the system pressure has stabilised. The switch takes a

pressure reading every 10 seconds and if it finds six readings within the set point margins it then averages these readings and calculates the set point and locks in the over and under margins. If it cannot find six readings within the allocated time it will shut down and display “pressure not stable”. If it encounters any outside the margins it will discard them and look for other readings inside the margin. Once six readings are detected within the margin the IPG20 will terminate the learning process and lock in the set point.

PRESSURE DIP TIMER

The time allowed if a low pressure is detected before the switch shuts the pump down. Once the set point is locked in the IPG20 enters normal running. Normal running is a condition where the system pressure is between the low-pressure set point and the high-pressure set point and flow is present. In this state, the IPG20 monitors both flow and pressure and ensures the system is operating properly and remains within the set parameters. If the system pressure falls below your low pressure set point the IPG20 reverts to running the pressure dip timer.

The purpose of the pressure dip timer is to let the pump system tolerate minor dips in pressure without shutting down the pump. Minor dips in pressure can be caused by valves opening and closing in irrigation systems and for a variety of reasons. Without the pressure dip timer such minor pressure fluctuations would trigger an instant pump shut down. The pressure dip timer is an automatically self-terminating timer with an adjustment range of 0 to 240 seconds (0 to 4 minutes) in 1 second increments. The IPG20 is supplied with the dip timer pre-set to a default value of 10 seconds. Increase or decrease this value to suit your system using the up or down buttons and then press (P) to confirm your setting and to move to the next main menu question.

PRESSURE SPIKE TIMER

The time allowed before the pump is stopped if a high pressure is detected. This is over-ridden by the absolute high setting. If the pressure rises to the absolute high value it will stop the pump instantly. Once the set point is locked in the IPG20 enters normal running. Normal running is a condition where the system pressure is in between the low-pressure set point and the high-pressure set point and flow is present. In this state the IPG20

monitors both flow and pressure and ensures the system is operating properly and remains within the set parameters. If the system pressure rises above the high pressure set point the IPG20 reverts to running the pressure spike timer. The purpose of the pressure spike timer is to let the pump system tolerate minor rises in pressure without shutting down the pump. Minor rises in pressure can be caused by valves opening and closing, or partial blockages. Without the pressure spike timer such minor pressure fluctuations would trigger an instant pump shut down. The pressure spike timer is an automatically self-terminating timer with an adjustment range of 0 to 240 seconds (0 to 4 minutes) in 1 second increments. The IPG20 is supplied with the dip timer pre-set to a default value of 10 seconds. Increase or decrease this value to suit your system using the up or down buttons and then press (P) to confirm your setting and to move to the next main menu question.

RUN-ON TIMER

The IPG20's built in run-on timer can be set to ignore minor interruptions to flow. For example, if air trapped in the pipework passes the pump guard's paddle the paddle will momentarily swing into the no-flow position. This would normally cause the pump guard to shut down the pump. The run-on timer lets the pump guard ignore such minor fluctuations in flow. Once triggered the run-on timer tries to keep the pump running for whatever time you have set it to, regardless of lack of flow.

During its run period, the run-on timer monitors the state of the paddle and if the paddle is pushed back into the on position by flow, the run-on timer cancels its run and resumes normal running. If, however, the interruption to flow persists for longer than you have set the run-on timer to, then at the end of the run-on time the IPG20 will shut the pump down. The run-on timer can be set to any value from 0 – 900 seconds (0 – 15 minutes) in increments of 1 second.

For most applications an initial setting of a few seconds is quite adequate. The self-resetting action of the run-on timer means it will keep a pump running in spite of repeated or continuous interruptions to flow. In applications where entrained gas is present in the water, the run-on timer will ignore the continuous bouncing back and forward of the paddle by constantly resetting its time clock instant by instant.

Once running, the controller runs for whatever time you set it too in cyclic running and then stops. As soon as it stops it closes the alarm relay contacts (if you have set it to valve sequencing mode). The contacts remain closed for the duration of the stopped time and then open. In valve sequencing mode it displays the message “VALVE SEQUENCING (Min to go)” rather than “FIXED STOP TIME (Hrs to go)” as it does in normal cyclic running. This is simply to differentiate valve sequencing from normal cyclic running.

Each time the switch restarts the system after the stop time it will reapply the set point learnt in the initial start-up process unless valve sequencing has been selected in which case “Relearn the pressure” can be used to accommodate changes in pressure due to zone changes.

AUTO RESTART ON A FAULT

The system can be restarted automatically after a fault condition has shut the pump off. The switch will only restart the pump once after a predetermined time, and if the fault reoccurs it will stay off and close the alarm relay if that option is selected. This option is not available if auto terrain compensation is selected.

ACCEPT SETTINGS

This is the end of the menu. Select “Yes” to confirm all your previous settings or use the (v) (^) buttons to select “No” to return to the top of the menu. If you accept “Yes” and press (P) you are then asked to press the Reset (R) button to start the pump. The IPG20 will start the pump and attempt to run the system using the settings you have programmed in. If the settings you have initially made prove unsatisfactory then simply pressing and holding down the (P) button for about 1 second and then releasing it will shut the pump down and take you to the top of the menu where you can step through the settings and make appropriate changes.

CYCLIC RUNNING

The IPG20 can be programmed to run and stop a pump for set periods of time. Both the running and stopping times can be set to any value you choose, from 1 minute - 99 hours 59 minutes (0 - just over 4 days) in increments of 1-minute. The cyclic running option is highly flexible. The run and stop timers are totally independent of each other. If a set running and stopping time are programmed in, the IPG20 will run the pump for whatever time it is set to and then stop for the time set on its stop timer. If a run time is set to some value and the stop time is left set at zero the pump guard will behave as a one-shot batch controller.

VALVE SEQUENCING

If you select to **“use the alarm relay”** and to also have it close its contacts **“whenever the pump is stopped”** then after entering a stopped time in cyclic running, a question will appear **“LEARN NEW PRESSURE (yes or no)”**. A user can choose to use valve sequencing or not, and if not, by selecting **“NO”** to the question, still have the alarm relay close its contacts when the pump stops in normal cyclic running.

AUTO RESTART ON A FAULT

The system can be restarted automatically after a fault condition has shut the pump off. The switch will only restart the pump once after a predetermined

TOTAL RUN TIME DISPLAY

The IPG20 keeps track of how long the pump runs for regardless of what it may be doing. On shutting down the pump for any reason the controller displays on its screen the total run time in minutes. The pump may have stopped because of high pressure or because flow was lost. Regardless of the reason and regardless of whether it ends up in permanent alarm or in auto restart waiting to restart, it displays the total time it previously ran for. In auto restart mode it does this by displaying alternate screens that change every 5 seconds.

One screen displays the reason for the shutdown and the time remaining before restart and the second screen displays the total run time. Total run time includes all peripheral times such as run-on and pressure dip time and the initial flow start and pressure start times. It also includes run time incurred during cyclic running. The run time display has a range of 1 minute

to 9999 minutes (about 7 days). The run time display automatically resets to zero each time the pump starts. The total run time display accumulates time at all times the pump is running. The total run time display is only reset to zero by a power interruption or by pressing the (R) reset button on the IPG20.

AUTO-RESTART, PERMANENT ALARM & THE ALARM RELAY

The alarm relay can be configured to close its contacts if one of ten fault conditions are encountered. The auto restart function in the IPG20 can be set to shut the pump down and restart after a delay time if one of eight fault conditions occur. The way the alarm relay responds to a fault and the way the controller in general responds to a fault are independent of each other.

It is therefore perfectly practical to have the controller shut down and either remain shut down or wait and automatically restart due to one fault condition while the alarm relay responds to a separate condition. For example, you could set the alarm relay to only close its contacts if the pump ran dry, and have the pump only automatically restart if it shut down due to low pressure.

NORMAL RUNNING

When the IPG20 is running the pump normally with flow present and with a line pressure that is in between the high-pressure and low-pressure trip points, the IPG20 displays information about the system on its screen. The screen displays your high and low pressure trip points in kPa. It also displays the current dynamic pressure in the pipe.

At a glance you can see precisely what the system is doing and where the pressure is in relation to your pressure trip points. In addition the IPG20 displays the flow status as a green or red flow light on its top deck and the state of the pump, red for stopped and green for running. If a remote input is connected between the LV and R terminals of the IPG20 and the external switch is closed, the blue remote input light on the top deck of the IPG20 will also be on.



If the IPG20 Mk2 is used in a manner not specified by the manufacturer the pump protection provided by the controller may be impaired or negated. In addition, all warranties stated or implied may be rendered invalid.

Warranty and Limitation of Liability

Thank you for purchasing Kelco Engineering Pty Ltd, (ABN 200 002 834 844) (“*Kelco*”) products (*Kelco Products*). This document sets out the terms and conditions of the product warranty and Limitation of Liability for *Kelco Products*. It is an important document. Please keep it with your proof of purchase documents in a safe place for future reference should you need to lodge a claim.

This Warranty and Limitation of Liability (or any more recent version in effect when you purchase a *Kelco Product*) (“**Warranty**”) applies to all *Kelco Products* regardless of where you purchased the *Kelco Products*.

When you place an order, you are deemed to agree to the *Warranty*, unless otherwise agreed in writing with *Kelco*.

Kelco is located at 9/9 Powells Road, Brookvale, NSW 2100, AUSTRALIA and may be contacted by calling 61 2 99056425 or emailing: sales@kelco.com.au

1. Definition

The following terms used herein are defined as follows:

- (1) *Australian Consumer Law* or *ACL*: Schedule 2 to the Competition and Consumer Act 2010 (Cth).
- (2) *Brochures and Technical data sheets*: *Kelco* brochures, including, without limitation, sales brochures and technical data sheets, whether or not provided electronically.
- (3) *Customer Application*: Any application of *Kelco Products* or component parts by a you including, but not limited to, embedding and/or using *Kelco Products* in your parts/components, electronic substrates, devices, equipment and /or systems manufactured by customers.

- (4) *Non- Excludable Guarantee*: a Consumer Guarantee applicable to these *Warranty Terms* under the *Australian Consumer Law* or *New Zealand Consumer Guarantee Act 1993*.
- (5) *Fitness*: (a) fitness for a particular purpose, (b) performance, (c) compliance with laws and regulations and (d) conformity to standards of a *Kelco Product*.
- (6) *Kelco Products*: flow switches, level switches and float switches, related products and electronic/mechanical components under the *Kelco* brand.
- (7) 'you' or "customer" means the purchaser of the *Kelco Products* not having purchased the *Kelco Products* for re-sale, and 'your' has a corresponding meaning.
- (8) *Usage Conditions*: Usage conditions, rating, performance, operating environment, handling instructions, warnings, restrictions on use, etc. of *Kelco Products* described in the *Brochures and technical data sheets*.

2. Descriptions

You are deemed to accept the following terms and conditions regarding the descriptions provided of Kelco Products in the Brochures and technical data sheets when you adopt or use a *Kelco Product* or component thereof.

- (1) Rated values and performance values are based on average performance established from batch production runs and *Kelco* does NOT warrant any rated values and performance values for multiple composite conditions.
- (2) Reference data is provided for your reference only. *Kelco* does NOT warrant that *Kelco Products* work properly at all times or continuously as provided in the reference data.
- (3) Application examples (if any) are provided for your reference only. *Kelco* does NOT warrant the *Fitness* of *Kelco Products* under such applications.
- (4) *Kelco* may discontinue the production of *Kelco Products* or change their specifications for the purpose of improving such products or for other reasons entirely at its own discretion and is under no obligation to notify you of any such change.

3. Precautions

You are deemed to accept the following terms and conditions when you purchase *Kelco Products*:

- (1) You will use *Kelco Products* in compliance with *Usage Conditions* including rating and performance.
- (2) You will confirm *Fitness* and use your own judgment to determine the appropriateness of using of *Kelco Products* in a *Customer Application*. *Kelco products* are unlike conventional flow and level switches and pump controllers in that they can be applied to virtually any fluid or pumping system in any manner defined by an original equipment manufacturer, a wholesaler or end user or their agents. The knowledge and experience of such parties is outside the control of *Kelco*, and their having relevant knowledge and experience is critical to the successful application and operation of the *Kelco Products*. ***Kelco does NOT warrant the Fitness of Kelco Products in a Customer Application.***
- (3) You will confirm that *Kelco Products* are properly wired and installed for their intended use in your overall system. In the case of *Kelco* pump controllers, the flexibility of their operating system means it requires an extensive knowledge of pumps and their characteristics and the intended overall goal of the system in order to select the correct functions and settings. Failure to understand the ramifications of incorrect settings may result in a system that fails to perform to your expectations and or may even damage the pump or system itself. It is therefore critical that correct settings are used to achieve a stable and reliable overall system and to provide any such system with appropriate pressure and or flow protection the pump controller is intended to provide. ***Kelco does NOT warrant Kelco Products against defective installation, incorrect programming, incorrect wiring or electrical overload in any form.***
- (4) When using *Kelco Products*, you will make sure to (i) maintain a margin of safety in relation to the published rated and performance values, (ii) design to minimize risks to any *Customer Application* in

case of failure of any *Kelco Products*, such as introducing redundancy i.e. critical systems should include double redundancy of all controls, (iii) adopt system-wide safety measures to notify risks to users such as independent backup protection. Such backup may consist of a simple or complex independent alarm system to alert an operator to any issue with the system, and (iv) conduct regular maintenance on *Kelco Products* and the *Customer Application*.

(5) It will be your sole responsibility as user to determine and use adequate measures and checkpoints to satisfy your particular requirements for (i) data input and output, (ii) maintaining a means for reconstruction of lost data, (iv) preventing *Kelco Products* installed thereon from being infected with computer viruses and (v) protecting *Kelco Products* from unauthorized access. ***Kelco shall not be responsible and/or liable for any loss, damage, or expenses directly or indirectly resulting from any third-party software or hardware not contained in the product as originally configured by the manufacturer, the infection of Kelco products, or any computer equipment, computer programs, networks, databases or other proprietary material connected thereto, by service attack, computer viruses, other technologically harmful material and/or unauthorized access.***

(6) *Kelco Products* are designed and manufactured as general-purpose products for use in general industrial products. They are not intended to be used in the applications described in subsection 3...(5)(a), (b), and (c). If you are using *Kelco Products* in the applications described below, ***Kelco does not provide any warranty for such Kelco Products, except for specific applications where Kelco has specified that it intends to provide a warranty or by separate written agreement between the customer and Kelco.***

- a. Applications with stringent safety requirements and applications that could cause physical injury to a person or result in loss of life.
- b. Applications under severe conditions or in severe environment, including but not limited to outdoor equipment, equipment exposed to chemical contamination, equipment exposed to electromagnetic interference and equipment exposed to vibration and shocks.
- c. Applications under conditions or environments not described in any of the Brochures and Technical data sheets.
- d. *Kelco Products* are not intended for use in Hydrocarbons other than Dieseline.

4. Warranty

Kelco warrants that *Kelco Products* will perform in accordance with the specifications set out in the Technical data sheets, subject to and in accordance with the following:

(1) Warranty period: The *Warranty* shall apply for 12 months from the date of original purchase of *Kelco Products* by the customer. .

(2) Sole Remedy: Unless required to do otherwise as a result of statutory guarantees applicable under *ACL*, *Kelco* will provide, at its own discretion, either of the following two services as the sole remedy for a malfunctioning *Kelco Product*:

Repair of the malfunctioning *Kelco Product(s)* or components by *Kelco* or *Kelco* authorised dealer at no charge to the customer, or

- a. Replacement of the malfunctioning *Kelco Product(s)* or components by *Kelco* or *Kelco* authorised dealer with the same number of replacement/alternative products or components at no charge to the customer.

(3) Exceptions: This *Warranty* of *Kelco Products* does not apply if the cause of the malfunction falls under any of the following:

- a. Usage in a manner other than the original intended use for the *Kelco Products* or component thereof.
- b. Usage other than as described in the *Usage Conditions*.
- c. Usage that is not in accordance with Section 2 (Descriptions) and Section 3 (Precautions) above.
- d. Modification or repair made to the *Kelco Products* by persons other than *Kelco*.
- e. Causes which could not have been foreseen with the level of science and technology at the time of shipping from *Kelco*.
- f. Replacement or repair of any (1) consumables (including cables, paddles and circuit boards), or (2) lost parts or accessories.
- g. Service of any product whilst it is outside Australia.
- h. Causes originating from other than *Kelco* or *Kelco Products* (including force majeure such as but not limited to natural disasters)
- i. Causes from any environmental factors. Such factors may include but are not limited to water or chemical ingress, fire damage, lightning damage, mechanical damage, sun damage or degradation, failure due to over-heating, freezing or vibration. Failure due to customers over tightening threads or fittings. Failure due to power supply fluctuations, surges, spikes, brown outs. or AC supplies that do not provide a pure sine wave output.

(4) If you intend to make a claim under this *Warranty* you must contact *Kelco* to register your claim by telephone on (02)99056425 and provide the following details to enable *Kelco* to assess the claim: (i) proof of purchase; (ii) evidence of the particulars of the claim that gives rise to the application of the *Warranty* ; (iii) confirmation that the cause of the malfunction was not an Exception set out above; and (iv) your phone number, email and address details.

You must provide or make the *Kelco product* available to *Kelco* for evaluation. If you are required to return the product to *Kelco* for repair replacement or evaluation, *Kelco* will provide delivery details and a return goods authorisation number to you. The *Kelco Products* will be at the owner's risk whilst in transit to and from *Kelco*, unless transported by *Kelco* or its authorised representatives.

The *Kelco Product* presented for repair may be replaced by refurbished products of the same type rather than being repaired. Refurbished parts may be used to repair the product.

To the extent permitted by law replacement of the product or a part does not extend or restart the *Warranty Term*.

***Kelco* may seek reimbursement of any costs incurred by them when the *Kelco product* is found to be in good working order.**

5. Non-excludable Statutory Guarantees

(1) The *Warranty* is given by *Kelco* in addition to other rights and remedies which you may be entitled to under by law, nothing contained in this agreement excludes, restricts or modifies any condition, guarantee, warranty or other obligation which is applicable to or is conferred on *Kelco* pursuant to law where to exclude, restrict or modify any such condition, warranty or other obligation is unlawful. (2) **Australia:** To the extent that you are a consumer for the purposes of the *ACL*, *Kelco Products* come with guarantees that cannot be excluded under the *ACL*. You are entitled to a replacement or refund for a major failure and compensation for any other reasonably foreseeable loss or damage. You are also entitled to have the goods repaired or replaced if the goods fail to be of acceptable quality and the failure does not amount to a major failure. "Acceptable Quality" and "major failure" have the meaning they have in the *ACL*. (3) **New Zealand:** For *Kelco Products* provided by *Kelco* in New Zealand, the *Kelco Products* come with a guarantee by *Kelco* pursuant to the provisions of the Consumer Guarantees Act, section 345(1)(i) of the Contract and Commercial Law Act 2017 and the Fair Trading Act. Where the *Kelco Product* was purchased in New Zealand for commercial purposes the Consumer Guarantee Act does not apply.

6. Disclaimer and Limitation of Liability

TO THE EXTENT PERMITTED BY APPLICABLE LAW:

(1) SELLER MAKES NO WARRANTY, EXPRESS OR IMPLIED, OTHER THAN AS STATED IN SECTION 4 ABOVE AND SELLER DISCLAIMS AND EXCLUDES ANY WARRANTY OF ANY OTHER KIND. (2) THE SOLE AND EXCLUSIVE REMEDY FOR MALFUNCTIONING KELCO PRODUCTS SHALL BE AS SET FORTH IN SECTION 4. ABOVE. (3) *KELCO* AND THE DISTRIBUTORS OF *KELCO PRODUCTS* ARE NOT LIABLE FOR ANY DAMAGES WHICH MAY ARISE FROM OR BE RELATED TO *KELCO PRODUCTS*.

7. Confidentiality: You accept that if you make a *Warranty* claim, *Kelco* and its agents may exchange information in relation to you to enable *Kelco* to meet its obligations under this *Warranty*.

8. Export/ Import Controls

Customers of *Kelco Products* shall comply with all applicable laws and regulations of Australia and/or other relevant countries with regard to security export/import control, when exporting/importing *Kelco Products* and/or technical documents or providing such products and/or documents to a non-resident of Australia. At its discretion *Kelco* may not provide customers with *Kelco Products* and/or technical documents should they fail to comply with such laws and regulations.

PLEASE NOTE: Kelco Engineering Pty Ltd reserves the right to change the specification of this product without notice. Users will use their own judgment to determine the appropriateness of using of Kelco Products in an application, any safety measures required and that the product is properly installed for that application. To the extent permitted by law Kelco Engineering Pty Ltd disclaims and excludes all and any liability for the use of this product in any particular application or for defective installation. The Kelco IPG20 Mk2 is warranted against malfunction by a 12 month return to base manufacturer's warranty. Full details of our warranty and limitation of liability can be downloaded from: <http://www.kelco.com.au/warranty>.

Designed and Manufactured in Australia by

KELCO Engineering Pty Ltd

A.B.N. 20 002 834 844

Head Office and Factory: 9/9 Powells Road Brookvale 2100 Australia

Postal Address: PO Box 7485 Warringah Mall NSW 2100

Phone: +61 2 99056425 Fax: +61 2 99056420 Email: sales@kelco.com.au

Web: www.kelco.com.au

