

INSTALLATION AND OPERATION INSTRUCTIONS FOR THE MF20 MICRO FLOW SWITCH

INTRODUCTION

The MF20 micro flow switch is a vertically mounted in line piston flow switch that is supplied preset to switch on or off at a specific flow rate. The body of the switch contains a piston that obstructs the line of flow. The process fluid, either a liquid or a gas enters the bottom of the switch and must push the piston up until it can flow over the piston and out the top of the switch. When the piston is pushed up by flowing fluid, a magnet inside the piston actuates a reed switch in the electrical enclosure; this provides a set of closed, (or open) electrical contacts that can be used in control circuits, to indicate flow. When flow stops the piston sinks down, due to gravity and in doing so, moves the magnet out of proximity of the reed switch, thus de-actuating the reed switch.

OPERATING ENVIRONMENT

The MF20 micro flow switch has no metal parts in contact with the process fluid. Inert thermoplastics are all that come in contact with the liquid passing through the switch. This means the MF20 can be used in aggressive chemical solutions and in many fluids that would attack metal parts. The MF20 flow switch contains a close fitting piston, and should only be used in applications where the process fluid is reasonably clean and free of entrained or suspended material. Fluids containing large particulate matter, ferrous materials or fibrous matter should not be used in this switch. If the degree of contamination of the process fluid can't be guaranteed, then suitable line filtration should be fitted to the system downstream of the MF20 flow switch. The principle environmental limitations of the MF20 micro flow switch are set out in the following table

Maximum Recommended Operating Pressure (Static or Dynamic) at Ambient Temperature	1800 kPa (260 P.S.I.)
Minimum Burst Pressure at Ambient Temperature	9700 kPa (1400 P.S.I.)
Maximum Liquid Temperature (Standard MF20 Switch)	60 Degrees C at a pressure 1 bar absolute, see note below
Minimum Liquid Temperature (Standard MF20 Switch)	-30°C
Maximum Recommended Continuous Flow Rate (Water)	25 Litres per Minute (Head loss across the switch <100kPa at 25L/min)
Liquid Ph range	1 to 14
Ingress Protection Rating (Weatherproof Rating)	IP67

IMPORTANT NOTE: Temperature for the maximum operating pressure shown in the above operating environment table is 15°C, In the interest of safety, maximum operating pressure must be de-rated linearly in direct proportion to temperature increase, to a maximum pressure of 1 bar absolute at 80 degrees Centigrade. In other words only use this switch at elevated temperatures in non pressurised systems that are totally open to atmosphere in all circumstances and under all conditions.

CHEMICAL COMPATIBILITY

The MF20 micro flow switch is constructed from glass reinforced Polypropylene with Viton O-ring seals. Specific data on the chemical compatibility of Polypropylene and Viton can be obtained from widely available chemical compatibility charts, or from Kelco, on request.

IMPORTANT: Never use this flow switch with the following reagents.

- 1) Sodium Hypochlorite at >10% concentration.
- 2) Ferrous or Ferric solutions (Ferric Chloride etc.)
- 3) Solvents or hydrocarbon or alcohol solutions of any kind.
- 4) Sulphuric Acid at >50% concentration.
- 5) Nitric Acid > 20% concentration

INSTALLATION

The MF20 micro flow switch must be mounted vertically in the pipe work, with flow passing upward through the switch body. There is a direction of flow arrow on the switch body; this directionality must be adhered to, as the switch will not operate

against a reversed flow. A comprehensive selection of pipe spigots and tube flare fittings are supplied with each switch. In most instances these fittings will prove sufficient to allow installation of the switch without the need for any special components. Pipe work can be used to support the switch, or the switch can be connected directly onto the discharge valve of a metering pump. The MF20 is terminated with 3/4" BSPP male threads. These can be screwed directly into pipe sockets, and used in 3/4" piping. In addition the switch is supplied with 3/4" unions and 1/2" (15NB) spigots. The spigots are thick walled and designed to be tapped 1/4BSP, for use with compression fittings, if required. The pipe spigots supplied with this switch constructed from PVC. Both types are suitable for solvent gluing directly into 15N/B PVC or ABS pipe fittings. In addition to the pipe spigots, each MF20 flow switch is supplied with 3 sets of tube flare fittings, these suit 6 by 4, 8 by 4 and 12 by 9 flexible tube.

FLOW SENSITIVITY & RESPONSE TIME

Sensitivity to fluid flow is a function of liquid viscosity and piston clearance. There are 3 pistons available to suit the MF20 flow switch. Each piston has a distinct switching point. The pistons are designated and marked A, B and C. The MF20 micro flow switch is supplied as standard with the "A" piston. The optional "B" and "C" pistons are also supplied with each switch. The following table sets out the performance parameters of the 3 pistons. The data is based on testing with water at 15°C as the test medium, and is accurate to +/-15%. Changes in liquid viscosity will affect the switching point. Increases in viscosity will proportionally decrease the flow rate required to actuate the

switch, and will proportionally increase the response time. Decreasing viscosity will proportionally increase the flow required to actuate the switch, and will proportionally decrease the response time. Pistons are changed by unscrewing the inlet adaptor (part No 2), and inserting the new piston.

Note: the spanner octagon on the inlet adaptor accepts a standard gas cylinder spanner (28mm across the flats). **Note:** In pulsed flow applications where no pulse dampener is installed, and the pulse frequency is less than the electrical response time, the MF20 flow switch may respond with a train of on/off pulses rather than with a continuous on signal.

Data in the table below refers to the MF20-B and MF20-R models only. When using the MF20-C, for any given piston, multiply the switching flow rates in the table by 2.0 to obtain the correct values.

Piston Markings and Designation	Switching Point on a Rising Flow In Litres Per Hour	Switching Point on a Reducing Flow in Litres Per Hour	Electrical Response Time in Seconds on Cessation of Flow
A	0.32 +/- 15%	0.30 +/- 15%	4
B	3.10 +/- 15%	3.05 +/- 15%	3
C	12.8 +/- 15%	12.6 +/- 15%	2

Please Note: The type "A" piston is supplied as standard fitted to each switch, unless otherwise specified. The B & C pistons are included packed in with the switch.

ELECTRICAL

The MF20 micro flow switch is available in a variety of electrical configurations, to suit specific applications. The model numbers and details of these options are outlined in the table below. The model of a specific switch can be found on a label inside the lid of the electrical housing of every switch.

OPERATING PARAMETERS

The electrical enclosure on the MF20 switch is accessible by removing one screw on the lid. The lid has an integral 20mm cable gland designed to accept flexible cable up to 10mm diameter, or the gland nut can be removed and the exposed female thread will then accept a 20mm conduit bush. Various electrical options are available for the MF20 flow switch. Details of the specific circuit board module, including its model number are located inside the lid of the electrical housing of each switch. All the available electrical modules use a reed switch as the primary switching element. The contacts of the reed switch open and close in response to the position of the switch piston magnet. The reed switch may be the primary switch, or it may be used to drive a triac or a relay that is included on the circuit board in the switch. Where the reed switch is used as the main switch, care should be taken to ensure it is not overloaded. Reed switches are very reliable devices but may be damaged easily if overloaded. Use interposing relays and avoid inductive loads, fit suitable protection such as diodes or rate effect suppression circuits. Avoid capacitive coupling effects associated with long cable runs, use shielded cable in such situations, and fit diode protection to the reed switches in DC applications.

The MF20 switch can be tested for electrical function in the following way. With the switch isolated and held vertically, place a continuity tester across terminals S1 and S2. (Do not use a lamp tester for this, due to the high inrush current.) Use a pencil or similar object to lift the piston within the switch. Each time the piston is lifted a closed circuit should appear across S1 and S2. The piston is accessed by pushing the pencil straight up the centre of the switch, through the centre of the inlet fitting. This test should be done dry, and without the switch in the pipe work. Each time the piston is released it should fall freely to the off position, and the switch should respond with an open circuit across terminals S1 and S2.

MAINTENANCE

This flow switch is a very low maintenance device. If the MF20 flow switch is correctly installed and if the process fluid is compatible with the materials of construction of this switch, then a very long service life can be expected. Factors that may contribute to early failure of this device include excess temperature, excess pressure or electrical loads in excess of the electrical modules ratings.

The MF20 in line flow switch is available in a variety of electrical configurations, to suit specific applications. The model numbers of these options are outlined in the table below.

Switch Model	Module Type	Contact Configuration	Switched Power maximum	Switched Voltage Maximum	Switched Current Resistive AC (rms) Maximum	Inductive Loads (Power Factor 0.4)	Typical Application
MF20-B	Dry Reed Switch	S.P.S.T N.O	40W	240V AC 200V DC	1A	Not Suitable	PLC and General Control Circuits
MF20-C	Dry Reed Switch	S.P.D.T Break before make	20W	140V AC 150V DC	1A	Not Suitable	PLC and General Control Circuits
MF20-R	Solid State Relay (Triac)	S.P.S.T N.O	750W	2 to 240V AC	4A Continuous (Spike to 15A)	4A at 240V AC	AC Control Circuits and AC Motor Control to 1HP

NOTE: The MF20 micro flow switch uses reed switches as the primary switching element. Reed switches are one of the most reliable mechanical switching devices ever devised. They offer an operating life in excess of 100 million cycles, however, care needs to be taken to ensure they are not electrically overloaded or if applied in questionable applications, suitable protection should be added to the control circuit.

All of the components of this switch are available as spare parts, as listed below

ITEM	DESCRIPTION	QTY	MATERIAL
1	SWITCH BODY	1	GLASS REINFORCED POLYPROPYLENE
2	INLET ADAPTOR	1	GLASS REINFORCED POLYPROPYLENE
3	O RING SEAL	2	EPDM ELASTOMER
4	MAIN LID GASKET	1	SANOPRENE
5	CABLE GLAND NUT	1	GLASS REINFORCED POLYPROPYLENE
6	CABLE GLAND THRUST RING	1	GLASS REINFORCED POLYPROPYLENE
7	CABLE GROMMET	1	SANOPRENE
8	LID	1	GLASS REINFORCED POLYPROPYLENE
9	LID FIXING SCREW	1	M5 BY 16 STAINLESS STEEL
10	PISTON	1	GLASS REINFORCED POLYPROPYLENE
11	MAGNET CASE	1	GLASS REINFORCED POLYPROPYLENE
12	TERMINAL BLOCK	1	ACETAL RESIN
13	OUTLET ADAPTOR	1	GLASS REINFORCED POLYPROPYLENE
14	CIRCUIT BOARD FIXING SCREW	2	M4 BY 6 STAINLESS STEEL PAN HEAD
15	CIRCUIT BOARD ASSEMBLY	1	COMPLETE ELECTRICAL MODULE
16	UNION NUT	2	GLASS REINFORCED POLYPROPYLENE
17	20NB PIPE TAIL	2	PVC
18	O RING SEAL	2	EPDM ELASTOMER
19	12 BY 9 TUBE ADAPTORS	2	ABS
20	8 BY 4 TUBE ADAPTORS	2	ABS
21	6 BY 4 TUBE ADAPTORS	2	ABS

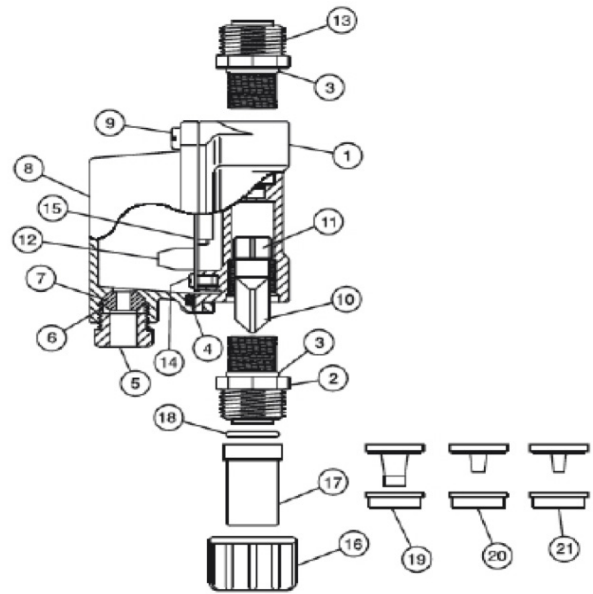

PARTS LIST MF20 MICRO FLOW SWITCH

KELCO Engineering Pty Ltd

ABN 20 002 834 844 Head office and factory: 9/9 Powells Road Brookvale NSW 2100 Australia. Postal Address: PO Box 7485 Warringah Mall Post Shop Brookvale NSW 2100 Australia. Phone: +61 2 9905 6425 Fax: +61 2 9905 6420 Email: Sales@kelco.com.au Web: www.Kelco.com.au

PLEASE NOTE: Kelco Engineering Pty Ltd reserves the right to change the specification of this product without notice. Users will use their own judgment to determine the appropriateness of using of Kelco Products in an application, any safety measures required and that the product is properly installed for that application. To the extent permitted by law Kelco Engineering Pty Ltd disclaims and excludes all and any liability for the use of this product in any particular application or for defective installation. This Kelco product is warranted against malfunction by a 12 month return to base manufacturer's warranty. Full details of our warranty and limitation of liability can be found in this document or downloaded from: <http://www.kelco.com.au/warranty>.